

EMERGENCY LIGHTING DEVICES FOR LED APPLICATIONS



ELECTRONIC EMERGENCY LIGHTING DEVICES WITH LITHIUM-ION BATTERIES

For nominal operating periods of 3 hours

Emergency lighting systems spring to life any time normal mains lighting systems fail. Emergency lighting is designed to ensure that staff can safely leave any rooms and that there is sufficient lighting to illuminate rescue paths/routes as well as to avoid panic situations.

VS emergency lighting devices are designed for use with LED applications and can be operated as part of a combined system with electronic LED drivers.



Emergency Complete

With or without self-diagnosis function and integrated battery

Product features

- Designed for operation of LED luminaires for safety lighting for rescue routes and extremely hazardous workplaces
- For emergency lighting for 3 hrs. operating time
- Suitable for emergency lighting acc. to VDE 0108 or EN 50172
- With self-diagnosis function acc. to EN 62034 (Self test witchable via Dip switch)
- Ambient temperature: 5 to 50 °C
- Lithium-ion (LiFePO4) rechargeable battery is built-in into the casing
- Charging time of rechargeable battery: up to 24 hrs. depending on the capacity

Electrical features

- Mains voltage: 220–240 V ± 10 %
- Mains frequency: 50–60 Hz
- Output voltage: 10-300 V
- Battery output power in emergency operation: 2.5 W

Safety features

- For luminaires of protection classes I and II
- Degree of protection: IP20
- Surge protection: 1 kV (between L and N) and 1 kV between (L/N and PE)

Status LED

- The system status is displayed with a bi-color indicator LED

Packaging units

Ref. No.	Packaging unit		
	Pieces per box	Boxes per pallet	Weight g
187552	40	54	287

A version with pre-installed cord grip is available on request.

Product guarantee

- 5 years on electronic parts
- The conditions for the Product Guarantee of the Vossloh-Schwabe Group shall apply as published on our homepage (www.vossloh-schwabe.com). We will be happy to send you these conditions upon request.

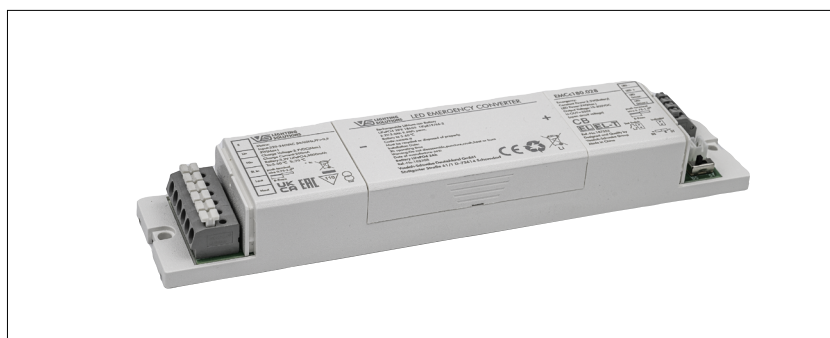

Dimensions

- Casing: K111
- Length: 200 mm
- Width: 39.6 mm
- Height: 25.5 mm

Used standards

- EN 60598-2-22
- EN 61347-2-7
- EN 62034
- EN 62384
- EN 61547
- EN 55015
- EN 61000-3-2/-3-3

K111

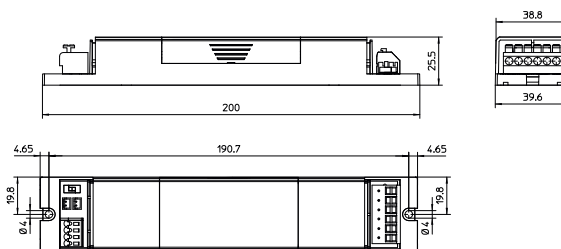

Cord grips K111

Available for independent operation
Contains two cord grips



Ref. No.: 187565

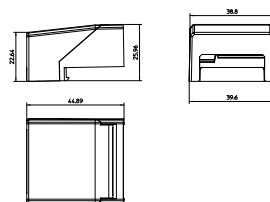

The values contained in this data sheet can change due to technical innovations. Any such changes will be made without separate notification.

LED Emergency Lighting Devices – Emergency Complete

Electrical characteristics

Type	Ref. No.	Battery	Nominal emergency operation period	Battery output power in emergency	Min. lumen in emergency	Output voltage	
		Type	hrs.	operation (W)	operation* (lm)	V	V max.

K111 – Dimensions (LxWxH): 200x39.6x25.5 mm

EMCc180.028	187552	3.2 V/3 Ah	3	2.5	250	10–300	350
-------------	--------	------------	---	-----	-----	--------	-----

* at 100 lm/W per LED unit

<p>VS LIGHTING SOLUTIONS</p> <p>Mains: Input:220-240VAC 50/60Hz,PF>0,9 3W(Max.) Charge Voltage:3.7VDC(Max.) Charge Current:200mA Battery:3.2V LiFePO4,3000mAh Ta:5-50 °C Tc:70 °C</p> <p>push terminal wire 0.75-1.5² 8-9mm</p> <p>UK CA EAC</p> <p>110</p>	<p>VS LIGHTING SOLUTIONS LED EMERGENCY CONVERTER</p> <p>Rechargeable Lithium-ion Battery LiFePO4 2IFR 18650 11FpR19/66-2 3.2V-3.0Ah 9.6Wh perm. Battery to 5-60 °C Code:XXXXXX** Must be recycled or disposed of properly. Installation Date: 3h operating time Warning:Do not disassemble,puncture,crush,heat or burn Date of manufacture: YYMM Battery LiFePO4 3Ah Ref.-No.183208 Vossloh-Schwabe Deutschland GmbH Stuttgarter Straße 61/1 D-73614 Schorndorf www.vossloh-schwabe.com</p> <p>CE RECYCLE Li</p>	<p>EMCc180.028</p> <p>Ref.-No.187552 Emergency: Output Power:2.5W Output Voltage:10-300VDC U-OUT=350V (open circuit voltage)</p> <p>CB</p> <p>EL-EL-T</p> <p>Designed and Quality by Vossloh-Schwabe Group Made in China</p>	<p>LED - LED + LED Driver- LED Driver+</p> <p>push terminal wire 0.75-1.5² 8-9mm</p> <p>Indicator</p> <p>Test Switch</p> <p>BS ST</p>
----------------------------------------------------------------------------------------------------------------------------------------------------------------------------------------------------------------------------------------------------------------------------------------------------------------------------	------------------------------------------------------------------------------------------------------------------------------------------------------------------------------------------------------------------------------------------------------------------------------------------------------------------------------------------------------------------------------------------------------------------------------------------------------------------------------------------------------------------------------------------------------------------------------------------------------------------------------------------------------	-------------------------------------------------------------------------------------------------------------------------------------------------------------------------------------------------------------------------------------------------------------------------------	------------------------------------------------------------------------------------------------------------------------------------------------------------------

Status LED

LED indication	Status	Description
Permanent green	Standby, System OK	Mains Operation ,battery is charged
Fast flashing green (0.25 s on 0.25 s off)	Function test in progress	Function test in progress
Slow flashing green (1 s on 1 s off)	Duration test in progress	Duration test in progress
Permanent red	Lamp failure	Open Circuit, Short circuit or LED failure
Fast flashing red (0.25 s on 0.25 s off)	Battery capacity failure	Battery failed duration test
Slow flashing red (1 s on 1 s off)	Battery fault	Incorrect battery voltage, short circuit or open circuit
Green and red off	Battery operation	Emergency mode: Mains disconnected or failure of the mains voltage power supply

Note:

Fault status:

If an error is detected, the indicator LED will switch to red. If the error has been corrected please re-connecting the battery after the mains power off, the indicator LED immediately will switch back to green when mainspower on.

Battery failed duration test:

After an exchange of the battery and holding down the button (>10 s) reset the timer, the indicator LED will switch to green.

The values contained in this data sheet can change due to technical innovations. Any such changes will be made without separate notification.

Assembly and Safety Information

Installation must be carried out under observation of the relevant regulations and standards. Installation must be carried out in a voltage-free state (i.e. disconnection from the mains). The following advices must be observed; non-observance can result in the destruction of the LED emergency lighting devices, fire and/or other hazards.

Mandatory regulations

- DIN VDE 0100
- EN 60598-1

Mechanical mounting – Emergency Complete

- Mounting position: Outside of an LED luminaire; suitable for independent operation
- Fastening: Using two suitable screws
- Ambient temperature: max. 50 °C
- Length of the status LED lead: 500 mm

Electrical installation

- Connection terminals PRI (E, Lin, Nin, SLin, Lout, Nout): Push-in terminals for leads of 0.75-2.5 mm²
- Connection terminals SEC (LED Driver +/-, LED +/-): Push-in terminals for leads of 0.75-1.5 mm²
- Stripped length: 8–9 mm
- Battery discharge current: The deep discharge protection of all lithium ion batteries is lower than 10 µA. This makes deliveries with connected battery possible, as long as no logistics restrictions apply.
- Polarity: Please ensure the correct polarity of the leads prior to commissioning. Reversed polarity can destroy the modules.
- Secondary load (LED): The sum of forward voltages of LED loads has to be within the range of the values for the "Electrical Characteristics" mentioned in this datasheet.
- Wiring: During mains-powered operation, the current that flows into the LED luminaire is regulated by the LED driver.
During emergency lighting operation, the LED unit will be supplied by the battery. The current that is supplied by the battery during emergency lighting operation is converted into "LED current" by the Complete emergency lighting unit.
- Insulation: Double or reinforce insulation between supply and battery/ESS circuits and based on a working voltage of 250 V;
Insulation between battery circuits/test circuits and LED circuits fulfills basic insulation and based on a working voltage of 350 V.
Insulation between supply and LED circuits fulfills double insulation with a voltage above ELV (350V).

Wiring diagram

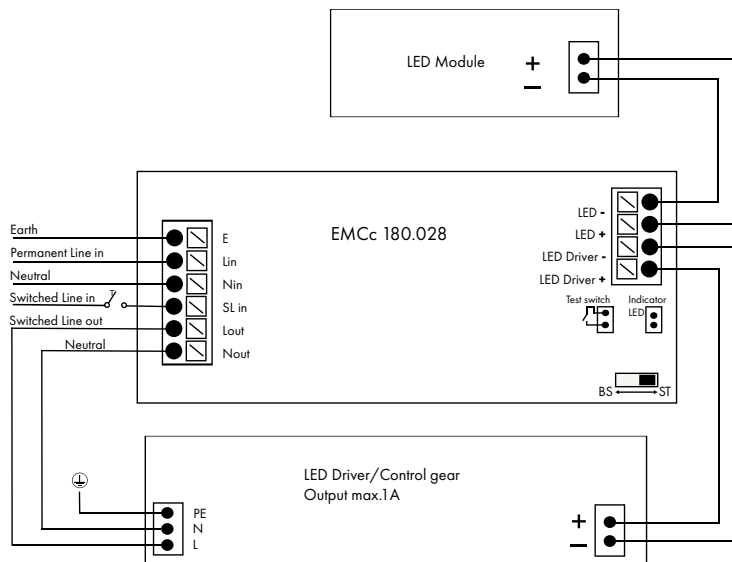

Testing/Commissioning (self test)

- Test button function: A short press (>1 s) on the button start a function test lasting 5 seconds (The battery's capacity should be more than 5 %=charging 30 minutes. Holding down the button(>10 s) resets the timer(System-reset)
- Function test: The 5 second long, each 7 days function test serves to check the functionality of the emergency unit, the batteries and LED module.

Notice: If a mains supply failure occurs while a function test is in progress, the test will be postponed and the system will enter emergency operation. Following restoration of the mains supply, a postponed functional test will re-commence automatically as soon as conditions permit.

- Duration test: First test: After 24 hours of AC mains power input, the emergency lighting unit will enter into a 3-hour duration test.
Half year duration test: Conduct 3-hour duration test every 180-182 days to check the battery capacity. If the duration test is successful, the indicator LED will flash green slowly within 5 days.
- Self-test: Self-testing function in acc. with EN 62034 included.
Every 7 days an automatic self-test will be carried out. During this time, the LED unit will be supplied by the battery for 5 seconds via the emergency device.
This ensures the LED unit and the correct functioning of the emergency lighting can be checked.

The values contained in this data sheet can change due to technical innovations. Any such changes will be made without separate notification.

LED Emergency Lighting Devices – Emergency Complete

Notice:

The indicator light will turn off under the following conditions:

1. When the power is off, the light enters the emergency mode.
2. Normal Function: When the power is on, the battery is disconnected.
3. After the power is connected, disconnect the power and reconnect the battery. (Note: in this case, please reset the AC power supply)

Requirements for LED Control gear:

the maximum output voltage shall not exceed 350 V, and the maximum current shall not exceed 1 A.

When the SLin is connected, the LED is in the maintenance state.

When the SLin is disconnected, the LED is in the no maintenance state.

Function switching:

Step 1: According to the diagram, switch the BS/ST function by the dip switch.

Step 2: Turn to the left and switch the function to standard version (BS).

Step 3: Turn to the right and switch the function to self-test version (ST).

Please note that functions switching by dip switch would only be available when all the wiring is disconnected, including the AC input, DC output and the battery

LED Output Behaviour During Emergency Operation

In emergency operation, the device automatically adjusts the LED current based on the total forward voltage of the connected LED modules. This characteristic behaviour is illustrated in the LED current versus forward voltage diagram, highlighting the typical current range across different load conditions.

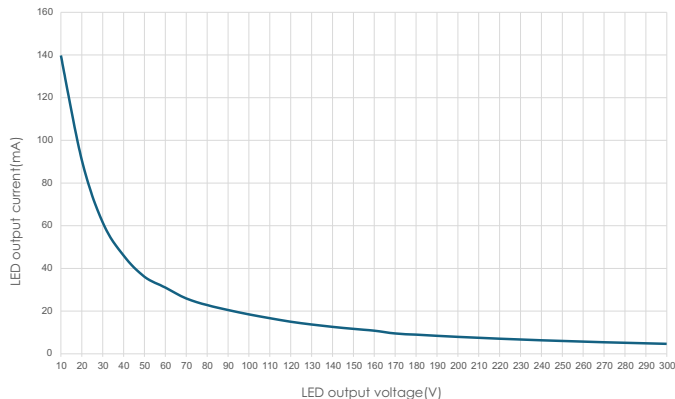

Accessory

Status indication

bi-colour LED:

Two-colour status display LED

green: system OK, red: fault

Plug connection

Opening size: 6 x 6 mm

Line length: 50 cm

Test switch:

For connection to the emergency lighting unit

For checking the device function

Plug connection

Dielectric strength: 500 V AC for 60 seconds

Opening size: 7.5 x 7.5 mm

Line length: 50 cm

The values contained in this data sheet can change due to technical innovations. Any such changes will be made without separate notification.

Batterys for Emergency Complete

Lithium-ion battery

Charging time of rechargeable batteries:
up to 24 hrs. depending on the capacity

This battery is a replacement.

A battery is included when you order the
EMCc180.028 187552 emergency kit.



Emergency Power W	Ref.No.	Rechargeable Lithium-ion Battery	Battery full charge time h	Charge current mA $\pm 10\%$	Battery discharge voltage Min-Typ-Max V	Battery discharge current Min-Typ-Max mA	Battery output power Min-Typ-Max W	Emergency duration h
2.5	183208	LiFePO4 2IFR 18650	16	200	2.5 - 3.2 - 3.6	650 - 740 - 840	1.9 - 2.4 - 2.7	3

Battery data

Capacity	3.0 Ah
International designation	IFpR 18/65
Battery voltage/cell	3.2 V
Cell type	18650
Case temperature range to ensure	
4 years design life	+5 °C to +55 °C
5 years design life	+5 °C to +45 °C
6 years design life	+5 °C to +35 °C
Max. short term battery case temperature (shorter than 1 month over the battery lifetime)	70 °C
Max. number discharge cycles	50 cycles total
Max. storage time	12 months

Automatically charge when the voltage of a single battery drops below 3.4 V.
When the voltage of a single battery exceeds 3.6 V, the charger turns off (0 mA).
If the battery temperature is above 60 ± 2 °C or below 0 ± 2 °C, the battery will stop charging.
The emergency lighting LED driver will recharge the battery normally after running the test of 61347-2-7 CL22.3 (abnormal operating conditions).
When the voltage of a single battery is below min 2.0 V, the battery will not enter an emergency state.
The minimum charging environment temperature of the battery is 5 °C, to ensure that the battery can be charged

Storage condition

Batteries should be stored within the specified temperature range in low humidity conditions.
Optimal storage conditions are
- Temperature: -20°C to +40°C
- Humidity: 45 % - 85 %
Avoid atmosphere with corrosive gas
It is recommended to disconnect the battery before storage or delivery
Battery should be charged every three months in order to keep it's initial performance.

Product guarantee

- 5 years on Battery
- The conditions for the Product Guarantee of the Vossloh-Schwabe Group shall apply as published on our homepage (www.vossloh-schwabe.com). We will be happy to send you these conditions upon request.

The values contained in this data sheet can change due to technical innovations. Any such changes will be made without separate notification.