



TALEXmodule LLE G1 24mm SNC-SE V4

TALEXmodule LLE ESSENCE

Technical data

| | |
|---|---------------------|
| Beam characteristic | 120° |
| Ambient temperature range | -20 ... +40 °C |
| tp rated | 65 °C |
| tc | 80 °C |
| Max. DC forward current | 360 mA |
| Max. permissible LF current ripple | 396 mA |
| Max. permissible peak current | 680 mA / max. 10 ms |
| Max. working voltage for insulation ²⁾ | 250 V |
| Insulation test voltage | 1.5 kV |
| CTI of the printed circuit board | ≥ 175 V |
| ESD classification | severity level 4 |
| Risk group (IEC 62471:2008) ³⁾ | 0 |
| Classification acc. to IEC 62031 | Built-in |
| Type of protection | IP00 |

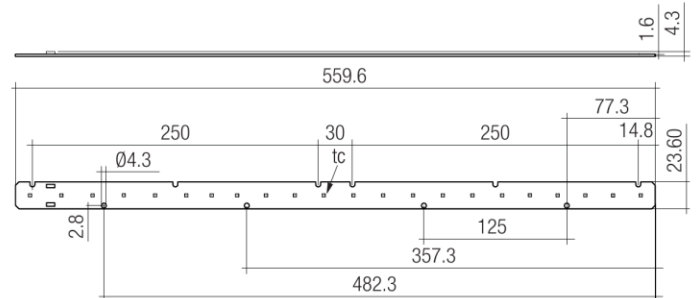

Ordering data

| Type | Article number | Colour temperature | Packaging carton | Weight per pc. |
|--------------------------------------|----------------|--------------------|------------------|----------------|
| LLE G1 24x560mm 1300lm 830 SNC-SE V4 | 87500487 | 3,000 K | 128 pc(s). | 0.04 kg |
| LLE G1 24x560mm 1300lm 840 SNC-SE V4 | 87500488 | 4,000 K | 128 pc(s). | 0.04 kg |
| LLE G1 24x560mm 1300lm 865 SNC-SE V4 | 87500489 | 6,500 K | 128 pc(s). | 0.04 kg |
| LLE G1 24x560mm 2400lm 830 SNC-SE V4 | 87500490 | 3,000 K | 128 pc(s). | 0.04 kg |
| LLE G1 24x560mm 2400lm 840 SNC-SE V4 | 87500491 | 4,000 K | 128 pc(s). | 0.04 kg |
| LLE G1 24x560mm 2400lm 865 SNC-SE V4 | 87500492 | 6,500 K | 128 pc(s). | 0.04 kg |

Specific technical data

| Type ¹⁾ | Photo-metric code | Typ. luminous flux at tp = 25 °C ²⁾ | Typ. luminous flux at tp = 45 °C ³⁾ | Typ. forward current | Min. forward voltage at tp = 65 °C | Max. forward voltage at tp = 25 °C | Typ. power consumption at tp = 45 °C ³⁾ | Efficacy of the module at tp = 25 °C | Efficacy of the module at tp = 45 °C | Efficacy of the system at tp = 45 °C | Colour rendering index CRI |
|--------------------------------------|-------------------|--|--|----------------------|------------------------------------|------------------------------------|--|--------------------------------------|--------------------------------------|--------------------------------------|----------------------------|
| Operating mode HE at 250 mA | | | | | | | | | | | |
| LLE G1 24x560mm 1300lm 830 SNC-SE V4 | 830/559 | 1,100 lm | 1,050 lm | 250 mA | 32.0 V | 36.0 V | 8.5 W | 129 lm/W | 124 lm/W | 111 lm/W | > 80 |
| LLE G1 24x560mm 1300lm 840 SNC-SE V4 | 840/559 | 1,150 lm | 1,120 lm | 250 mA | 32.0 V | 36.0 V | 8.5 W | 135 lm/W | 132 lm/W | 118 lm/W | > 80 |
| LLE G1 24x560mm 1300lm 865 SNC-SE V4 | 865/559 | 1,180 lm | 1,130 lm | 250 mA | 32.0 V | 36.0 V | 8.5 W | 139 lm/W | 133 lm/W | 119 lm/W | > 80 |
| LLE G1 24x560mm 2400lm 830 SNC-SE V4 | 830/559 | 2,200 lm | 1,950 lm | 250 mA | 62.0 V | 70.5 V | 16.6 W | 133 lm/W | 114 lm/W | 103 lm/W | > 80 |
| LLE G1 24x560mm 2400lm 840 SNC-SE V4 | 840/559 | 2,250 lm | 2,050 lm | 250 mA | 62.0 V | 70.5 V | 16.6 W | 136 lm/W | 123 lm/W | 111 lm/W | > 80 |
| LLE G1 24x560mm 2400lm 865 SNC-SE V4 | 865/559 | 2,300 lm | 2,100 lm | 250 mA | 62.0 V | 70.5 V | 16.6 W | 139 lm/W | 127 lm/W | 113 lm/W | > 80 |
| Operating mode HE at 280 mA | | | | | | | | | | | |
| LLE G1 24x560mm 1300lm 830 SNC-SE V4 | 830/559 | 1,220 lm | 1,080 lm | 280 mA | 32.0 V | 33.5 V | 9.0 W | 136 lm/W | 120 lm/W | 108 lm/W | > 80 |
| LLE G1 24x560mm 1300lm 840 SNC-SE V4 | 840/559 | 1,290 lm | 1,130 lm | 280 mA | 32.0 V | 33.5 V | 9.0 W | 143 lm/W | 126 lm/W | 113 lm/W | > 80 |
| LLE G1 24x560mm 1300lm 865 SNC-SE V4 | 865/559 | 1,300 lm | 1,150 lm | 280 mA | 32.0 V | 33.5 V | 9.0 W | 144 lm/W | 128 lm/W | 114 lm/W | > 80 |
| LLE G1 24x560mm 2400lm 830 SNC-SE V4 | 830/559 | 2,450 lm | 2,150 lm | 280 mA | 62.0 V | 70.5 V | 18.9 W | 130 lm/W | 114 lm/W | 102 lm/W | > 80 |
| LLE G1 24x560mm 2400lm 840 SNC-SE V4 | 840/559 | 2,500 lm | 2,190 lm | 280 mA | 62.0 V | 70.5 V | 18.9 W | 132 lm/W | 116 lm/W | 104 lm/W | > 80 |
| LLE G1 24x560mm 2400lm 865 SNC-SE V4 | 865/559 | 2,550 lm | 2,220 lm | 280 mA | 62.0 V | 70.5 V | 18.9 W | 135 lm/W | 117 lm/W | 105 lm/W | > 80 |
| Operating mode HO at 300 mA | | | | | | | | | | | |
| LLE G1 24x560mm 1300lm 830 SNC-SE V4 | 830/559 | 1,300 lm | 1,120 lm | 300 mA | 32.5 V | 36.5 V | 10.3 W | 126 lm/W | 109 lm/W | 97 lm/W | > 80 |
| LLE G1 24x560mm 1300lm 840 SNC-SE V4 | 840/559 | 1,370 lm | 1,200 lm | 300 mA | 32.5 V | 36.5 V | 10.3 W | 133 lm/W | 117 lm/W | 104 lm/W | > 80 |
| LLE G1 24x560mm 1300lm 865 SNC-SE V4 | 865/559 | 1,380 lm | 1,210 lm | 300 mA | 32.5 V | 36.5 V | 10.3 W | 134 lm/W | 117 lm/W | 105 lm/W | > 80 |
| LLE G1 24x560mm 2400lm 830 SNC-SE V4 | 830/559 | 2,600 lm | 2,200 lm | 300 mA | 61.9 V | 70.2 V | 19.9 W | 131 lm/W | 111 lm/W | 99 lm/W | > 80 |
| LLE G1 24x560mm 2400lm 840 SNC-SE V4 | 840/559 | 2,650 lm | 2,300 lm | 300 mA | 61.9 V | 70.2 V | 19.9 W | 133 lm/W | 116 lm/W | 104 lm/W | > 80 |
| LLE G1 24x560mm 2400lm 865 SNC-SE V4 | 865/559 | 2,700 lm | 2,350 lm | 300 mA | 61.9 V | 70.2 V | 19.9 W | 136 lm/W | 118 lm/W | 106 lm/W | > 80 |

¹⁾ Integral measurement over the complete module.

²⁾ If mounted with M4 screws (max. 8 mm head diameter).

³⁾ Measured at operating mode HO.

⁴⁾ HE ... high efficiency, HO ... high output.

⁵⁾ Tolerance range for optical and electrical data: ±10 %.

Product description

- LINEAR COVER for LLE 24
- Protection against direct touch for non-SELV applications
- Fast snap on mounting on to LLE 24 with clips or plastic washers
- High transmission: transparent 94 %, semi-transparent 87 %, diffuse 76 %
- Made of PMMA
- Tolerances: ± 1 mm for 597 mm length (ends finished),
+ 20 mm for 1,200 / 1,500 / 1,600 / 1,800 mm length (ends raw)

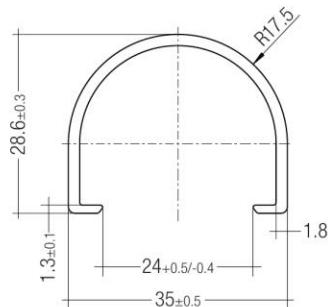
**Ordering data**

| Type | Article number | Colour | Length | Packaging carton | Weight per pc. |
|------------------------------------|----------------|------------------|----------|------------------|----------------|
| LINEAR COVER SY Transparent 1600mm | 28000338 | Transparent | 1,600 mm | 12 pc(s). | 0.272 kg |
| LINEAR COVER SY Frosted 1800mm | 28000437 | Semi-transparent | 1,800 mm | 12 pc(s). | 0.308 kg |
| LINEAR COVER SY Frosted 1600mm | 28000339 | Semi-transparent | 1,600 mm | 12 pc(s). | 0.272 kg |
| LINEAR COVER SY Frosted 1500mm | 28000435 | Semi-transparent | 1,500 mm | 12 pc(s). | 0.244 kg |
| LINEAR COVER SY Frosted 1200mm | 28000422 | Semi-transparent | 1,200 mm | 12 pc(s). | 0.205 kg |
| LINEAR COVER SY Frosted 597mm | 28000340 | Semi-transparent | 597 mm | 12 pc(s). | 0.102 kg |
| LINEAR COVER SY Diffuse 1800mm | 28000438 | Diffuse | 1,800 mm | 12 pc(s). | 0.308 kg |
| LINEAR COVER SY Diffuse 1600mm | 28000341 | Diffuse | 1,600 mm | 12 pc(s). | 0.272 kg |
| LINEAR COVER SY Diffuse 1500mm | 28000436 | Diffuse | 1,500 mm | 12 pc(s). | 0.257 kg |
| LINEAR COVER SY Diffuse 1200mm | 28000434 | Diffuse | 1,200 mm | 12 pc(s). | 0.205 kg |
| LINEAR COVER SY Diffuse 597mm | 28000342 | Diffuse | 597 mm | 12 pc(s). | 0.102 kg |

ACL ENDCAP LLE24 PUSH-FIX

Product description

- ENDCAP for LLE 24
- Fast snap on mounting (sheet thickness 0.5 – 1.0 mm), for drilling hole 4 mm
- Made of Polycarbonat

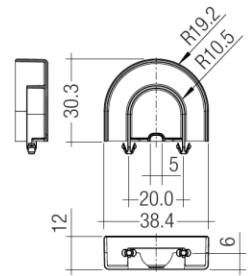

Ordering data

| Type | Article number | Colour | Packaging carton | Weight per pc. |
|---------------------------|----------------|--------|------------------|----------------|
| ACL ENDCAP LLE24 PUSH-FIX | 28001037 | White | 480 pc(s). | 0.003 kg |

LINEAR LENS

Product description

- Linear lens for LLE 24
- Available in 60° and 90° light distribution
- Protection against direct touch for non-SELV applications
- Fast snap on mounting on to LLE 24 with clips or plastic washers
- High transmission: semi-transparent 97 %
- Linear lense made of PMMA
- Tolerances: ± 20 mm for 1,600 mm length (ends raw)

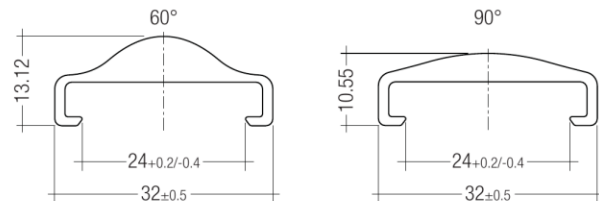

Ordering data

| Type | Article number | Colour | Length | Packaging carton | Weight per pc. |
|-------------------------------|----------------|-----------------|----------|------------------|----------------|
| ACL LINEAR LENS 24x1600mm 60° | 28000953 | Halbtransparent | 1,600 mm | 21 pc(s). | 0.261 kg |
| ACL LINEAR LENS 24x1600mm 90° | 28000955 | Halbtransparent | 1,600 mm | 21 pc(s). | 0.221 kg |

CLIP 4.3mm

Product description

- Clip for fixation of LED modules with 4.3 mm holes
- Fast snap on mounting (sheet thickness 0.5 – 1.0 mm)
- For drilling hole 4 mm
- Clip made of Polycarbonat

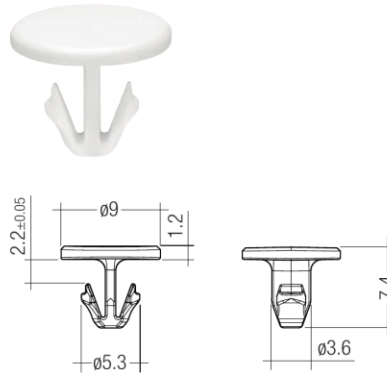

Ordering data

| Type | Article number | Colour | Packaging bag ^① | Weight per pc. |
|-------------------------|----------------|--------|----------------------------|----------------|
| ACL CLIP 4.3mm PUSH-FIX | 28001036 | White | 500 pc(s). | 0.001 kg |

^① Minimum sales quantity 500 pcs.

BRIDGE LLE24/40

Product description

- Enables the fixation of 24 mm wide Tridonic LED modules to fixtures made for 40 mm wide modules
- Ideal for extruded aluminium gear trays made for 40 mm modules with pre-alignment knobs
- Clip-on for LINEAR COVER and LINEAR LENS[®]
- For LLE 24 with 280 mm module minimum 2 bridges required
- For LLE 24 with 560 mm module minimum 3 bridges required
- Fixation via M3 or M4 countersunk screw, max. tightening torque 0.5 Nm
- BRIDGE made of white polycarbonate

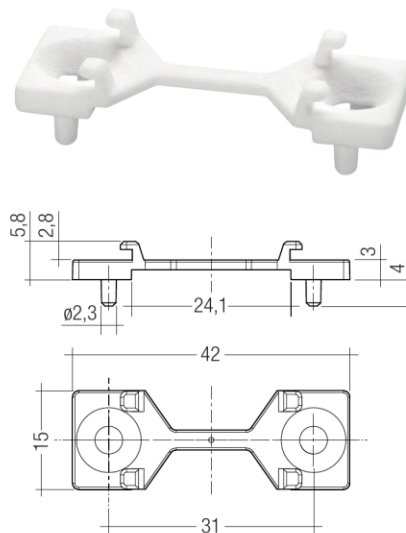

Ordering data

| Type | Article number | Colour | Packaging carton ^② | Weight per pc. |
|-------------------------------|----------------|--------|-------------------------------|----------------|
| ACL BRIDGE LLE24/40 SCREW-FIX | 28001205 | White | 600 Stk. | 0.001 kg |

^① Minimum sales quantity 600 pcs.

^② Beam characteristics will change due to the elevated fixation (see photometric files for details).

1. Standards

IEC 62031
IEC 62471
IEC 61000-4-2

1.1 Photometric code

Key for photometric code, e. g. 830 / 359

| 1 st digit | 2 nd + 3 rd digit | 4 th digit | 5 th digit | 6 th digit | |
|-----------------------|---|-----------------------|---|--|--------|
| Code CRI | Colour temperature in Kelvin x 100 | McAdam initial | McAdam after 25% of the life-time (max.6000h) | Luminous flux after 25% of the life-time (max.6000h) | |
| | | | | Code Luminous flux | |
| 7 70 – 79 | | | | 7 | ≥ 70 % |
| 8 80 – 89 | | | | 8 | ≥ 80 % |
| 9 ≥90 | | 9 | ≥ 90 % | | |

1.2 Energy classification

| Typ | Energieklassifizierung |
|----------------------------------|------------------------|
| LLE G1 24x560mm 1300lm SNC-SE V4 | A+ |
| LLE G1 24x560mm 2400lm SNC-SE V4 | A+ |

2. Thermal details

2.1 tc point, ambient temperature and life-time

The temperature at tp reference point is crucial for the light output and life-time of a TALEX product.

For TALEXmodule LLE a tp temperature of 65 °C has to be complied in order to achieve an optimum between heat sink requirements, light output and life-time.

Compliance with the maximum permissible reference temperature at the tc point must be checked under operating conditions in a thermally stable state. The maximum value must be determined under worst-case conditions for the relevant application.

The tc and tp temperature of LED modules from Tridonic are measured at the same reference point.

2.2 Storage and humidity

| | |
|---------------------|----------------|
| Storage temperature | -20 ... +80 °C |
|---------------------|----------------|

Operation only in non condensing environment.

Humidity during processing of the module should be between 30 to 70 %.

2.3 Thermal design and heat sink

The rated life of TALEX products depends to a large extent on the temperature. If the permissible temperature limits are exceeded, the life of the TALEXmodule LLE will be greatly reduced or the TALEXmodule LLE may be destroyed.

2.4 Heat sink values

Heat sink is required. The cooling of the module must be realised over the luminaire.

3. Installation / wiring

3.1 Electrical supply/choice of LED Driver

TALEXmodule LLE from Tridonic are not protected against overvoltages, overcurrents, overloads or short-circuit currents. Safe and reliable operation can only be guaranteed in conjunction with a LED Driver which complies with the relevant standards. The use of TALEXconverter from Tridonic in combination with TALEXmodule LLE guarantees the necessary protection for safe and reliable operation.

If a LED Driver other than Tridonic TALEXconverter is used, it must provide the following protection:

- Short-circuit protection
- Overload protection
- Overtemperature protection



TALEXmodule LLE must be supplied by a constant current LED Driver. Operation with a constant voltage LED Driver will lead to an irreversible damage of the module.

Wrong polarity can damage the TALEXmodule LLE.

If TALEXmodules LLE are wired in parallel and a wire breaks or a complete module fails then the current passing through the other module increases. This may reduce its life considerably. In addition there can be slight differences in light output caused by tolerances.

TALEXmodule LLE can be operated either from SELV LED Drivers or from LED Drivers with LV output voltage.



TALEXmodule LLE are basic isolated up to 250 V (if mounted with M4 screws with a head diameter of less than 8 mm) against ground and can be mounted directly on earthed metal parts of the luminaire. If the max. output voltage of the LED Driver (also against earth) is above 250 V, an additional isolation between LED module and heat sink is required (for example by isolated thermal pads) or by a suitable luminaire construction. At voltages > 60 V an additional protection against direct touch (test finger) to the light emitting side of the module has to be guaranteed. This is typically achieved by means of a non removable light distributor over the module.

3.2 Wiring

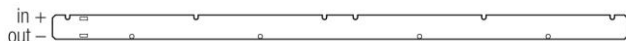

Wiring examples

Serial

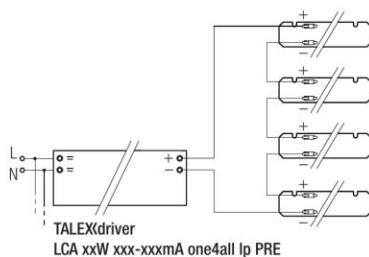

Parallel

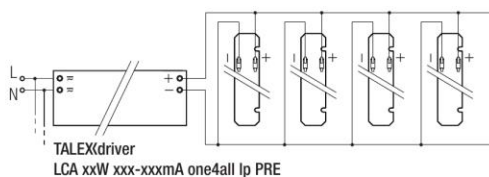

3.3 Wiring type and cross section

The wiring can be in stranded wires or solid with a cross section of 0.2 to 0.75 mm². For the push-wire connection you have to strip the insulation (8–9 mm).

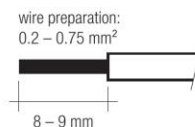

To remove the wires use a suitable tool (e.g. Microcon release pin) or through twist and pull.

3.4 Mounting instruction



None of the components of the TALEXmodule LLE (substrate, LED, electronic components etc.) may be exposed to tensile or compressive stresses.

Max. torque for fixing: 0.5 Nm.

The LED modules are mounted onto a heat sink with min. 3 screws per module. In order not to damage the modules only rounded head screws and an additional plastic flat washer should be used.



Chemical substance may harm the LED module. Chemical reactions could lead to colour shift, reduced luminous flux or a total failure of the module caused by corrosion of electrical connections.

Materials which are used in LED applications (e.g. sealings, adhesives) must not produce dissolver gas. They must not be condensation curing based, acetate curing based or contain sulfur, chlorine or phthalate. Avoid corrosive atmosphere during usage and storage.

3.5 EOS/ESD safety guidelines



The device / module contains components that are sensitive to electrostatic discharge and may only be installed in the factory and on site if appropriate EOS/ESD protection measures have been taken. No special measures need be taken for devices/modules with enclosed casings (contact with the pc board not possible), just normal installation practice. Please note the requirements set out in the document EOS / ESD guidelines (Guideline_EOS_ESD.pdf) at: <http://www.tridonic.com/esd-protection>

4. Life-time

4.1 Life-time, lumen maintenance and failure rate

The light output of an LED Module decreases over the life-time, this is characterized with the L value.

L70 means that the LED module will give 70 % of its initial luminous flux. This value is always related to the number of operation hours and therefore defines the life-time of an LED module.

As the L value is a statistical value and the lumen maintenance may vary over the delivered LED modules.

The B value defines the amount of modules which are below the specific L value, e.g. L70B10 means 10 % of the LED modules are below 70 % of the initial luminous flux, respectively 90 % will be above 70 % of the initial value. In addition the percentage of failed modules (fatal failure) is characterized by the C value.

The F value is the combination of the B and C value. That means for F degradation and complete failures are considered, e.g. L70F10 means 10 % of the LED modules may fail or be below 70 % of the initial luminous flux.

Life-time declarations are informative and represent no warranty claim.

4.2 Lumen maintenance for TALEX(module LLE G1 24mm SNC-SE

LLE G1 24x560mm 1300lm 8xx SNC-SE

| Forward current | tp temperature | L90 / B50 | L80 / B50 | L70 / B10 |
|-----------------|----------------|-----------|----------------|-----------|
| | | 250 mA | 45 °C 22,000 h | 30,000 h |
| | 65 °C | 22,000 h | 30,000 h | 30,000 h |
| 300 mA | 45 °C | 22,000 h | 30,000 h | 30,000 h |
| | 65 °C | 20,000 h | 30,000 h | 30,000 h |

LLE G1 24x560mm 2400lm 8xx SNC-SE

| Forward current | tp temperature | L90 / B50 | L80 / B50 | L70 / B10 |
|-----------------|----------------|-----------|----------------|-----------|
| | | 250 mA | 45 °C 11,500 h | 22,000 h |
| | 65 °C | 10,500 h | 19,500 h | 30,000 h |
| 300 mA | 45 °C | 11,000 h | 20,500 h | 30,000 h |
| | 65 °C | 10,000 h | 19,000 h | 30,000 h |

5. Electrical values

5.1 Typ. forward voltage vs. forward current

LLE G1 24x560mm 1300lm 8xx SNC-SE

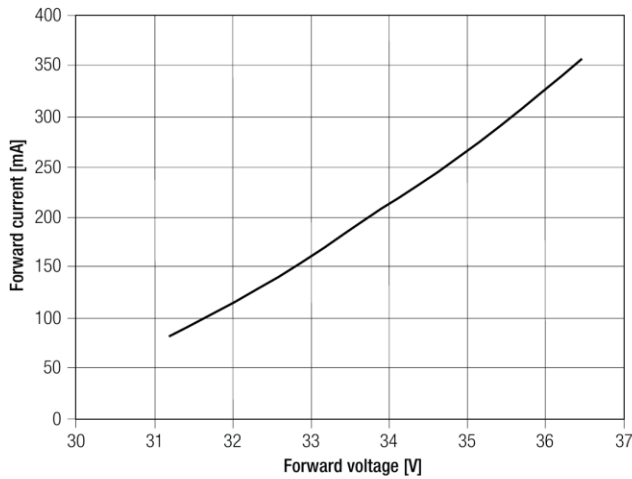

LLE G1 24x560mm 2400lm 8xx SNC-SE

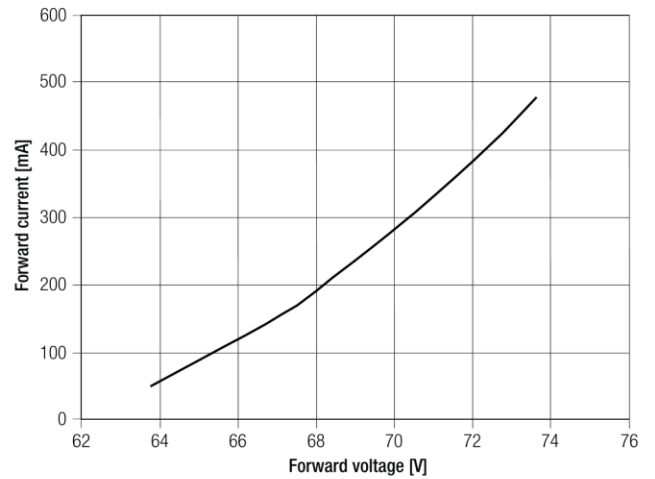

5.2 Forward voltage vs. tc temperature

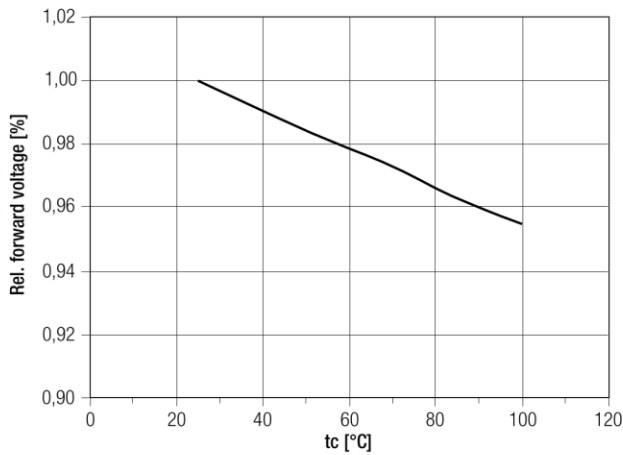

The diagrams are based on statistic values.
The real values can be different.

6. Photometric characteristics

6.1 Coordinates and tolerances according to CIE 1931

The specified colour coordinates are integral measured by current impulse of 325 mA and a duration of 100 ms.

The ambient temperature of the measurement is $t_a = 25^\circ\text{C}$.

The measurement tolerance of the colour coordinates are ± 0.01 .

3,000 K

| | x0 | y0 |
|--------|--------|--------|
| Centre | 0.4289 | 0.4017 |

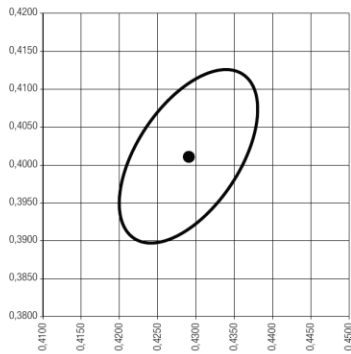

— MacAdam Ellipse: 5SDCM

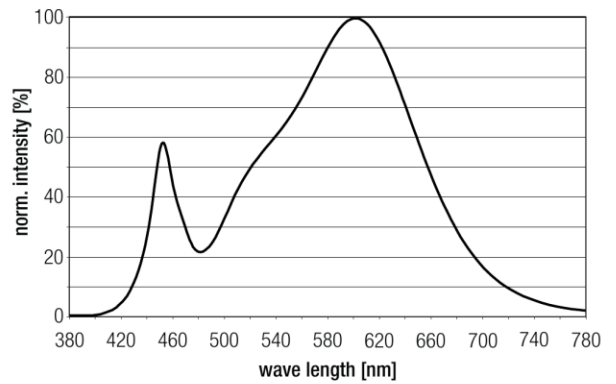

4,000 K

| | x0 | y0 |
|-------------|--------|--------|
| Mittelpunkt | 0.3763 | 0.3747 |

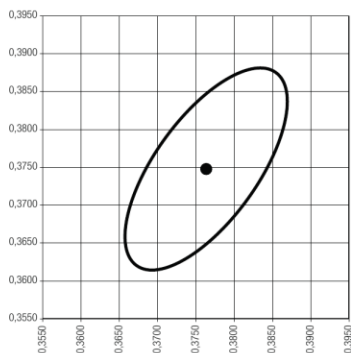

— MacAdam Ellipse: 5SDCM

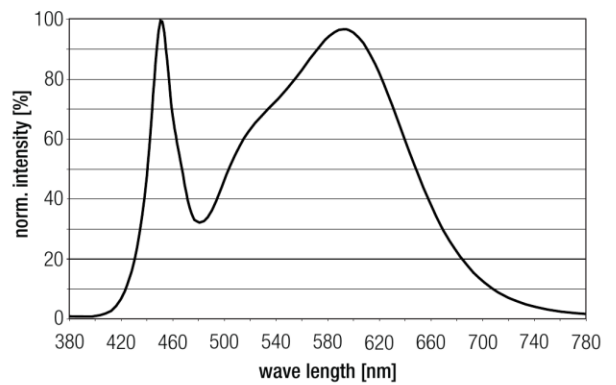

6,500 K

| | x0 | y0 |
|-------------|--------|--------|
| Mittelpunkt | 0.3060 | 0.3191 |

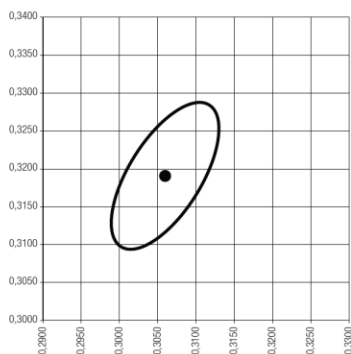

— MacAdam Ellipse: 5SDCM

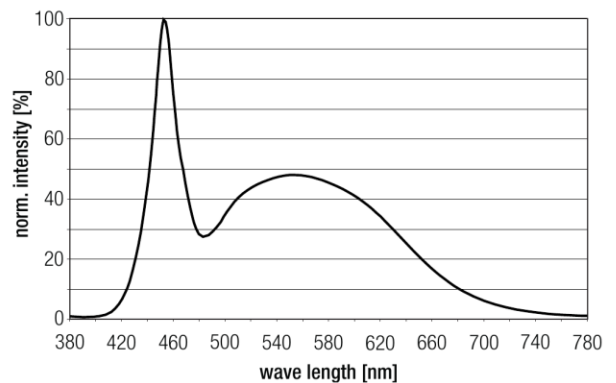

6.2 Light distribution

The optical design of the TALEX module LLE product line ensures optimum homogeneity for the light distribution.

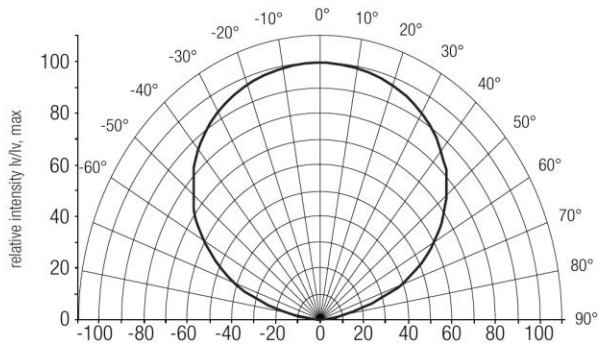

The colour temperature is measured integral over the complete module. The single LED light points can have deviations in the colour coordinates within MacAdam 5.

To ensure an ideal mixture of colours and a homogenous light distribution a suitable optic (e. g. PMMA diffuser) and a sufficient spacing between module and optic (typ. 4 cm) should be used.

For further information see Design-in Guide, 3D data and photometric data on www.tridonic.com or on request.

6.3 Relative luminous flux vs. tc temperature

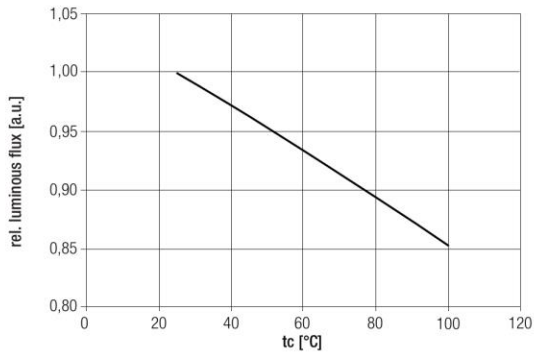

6.4 Relative luminous flux vs. operating current

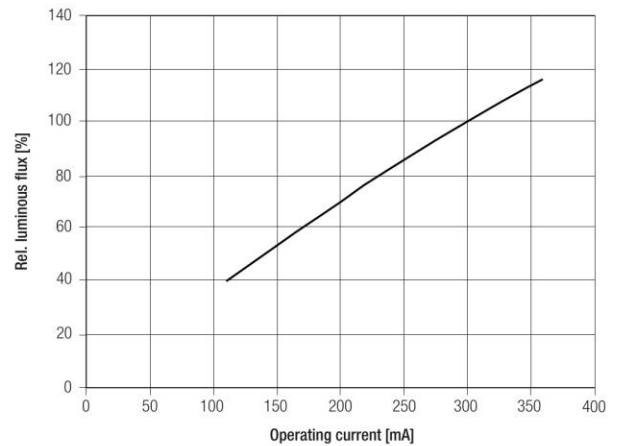

The diagrams are based on statistic values. The real values can be different.