

LED Flexible Strip 3528 Series LM2835-WN180-12V-8MM

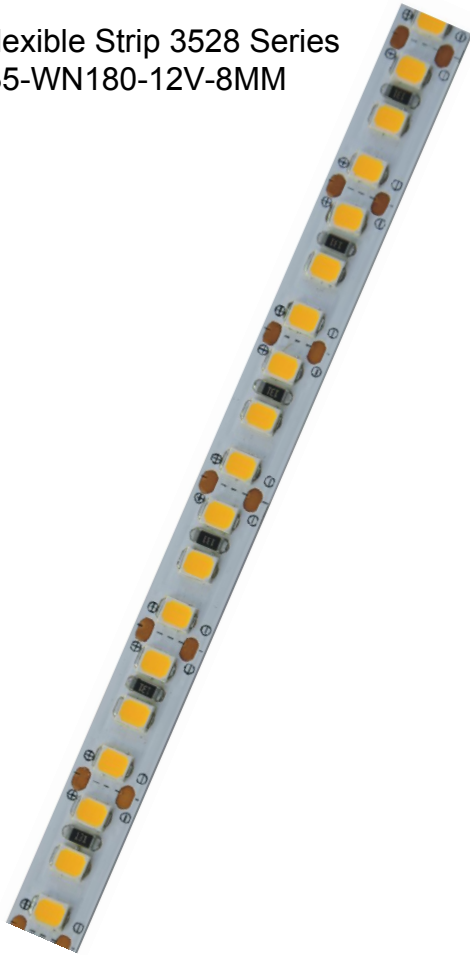

PRODUCT FEATURE

- ◆ **180**leds per meter,5meters per roll, the theoretical power**26** W/meter, Actual power: W/m ,light angle 120 degrees. **27-30**lm per led chip.Can be customized according to needed.
- ◆ Flexible, cuttable,back with 3M double-sided adhesive,can be installed in the concave convex surface, easy to install.
- ◆ Led strip supports external light regulator type: 0/1-10V PWM Dali Dimmable inductive switch controller.
- ◆ Cutting unit is **16.67**mm, **3** led chips can be used as a unit, cutting does not affect other parts. Normal length is 5 meters, other lengths also acceptable.
- ◆ Low power consumption, low fever, no glare, impact resistance, energy saving and environmental conservation.
- ◆ IP 20
- ◆ Life time: Mean time between failure(MTBF):50-100K hour

CE RoHS FC

TECHNICAL PARAMETERS

Mode	LED Q'ty/M	Color temperature	CRI(Ra)		Voltage (V DC)	Electric current (A/m)	Power± 10%(W/m)			Lm/m ± 10%	FPC Width
			Min	Max			Actual	Min	Max		
LM2835-WN180-12V	180	CCT: 3000K	80+	>93	12			6	18		8mm

DIMENSION (mm/inch)

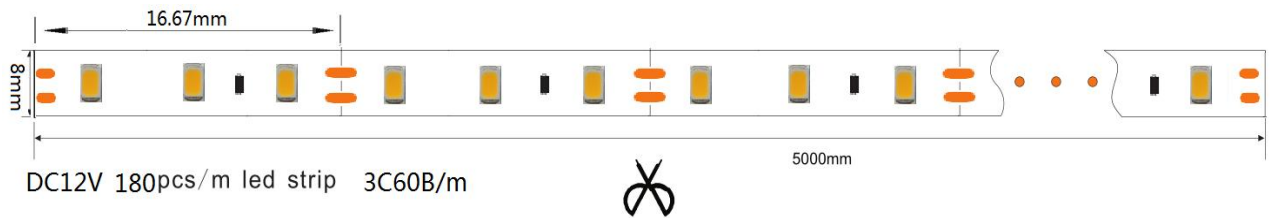

PRODUCT ELECTRICAL

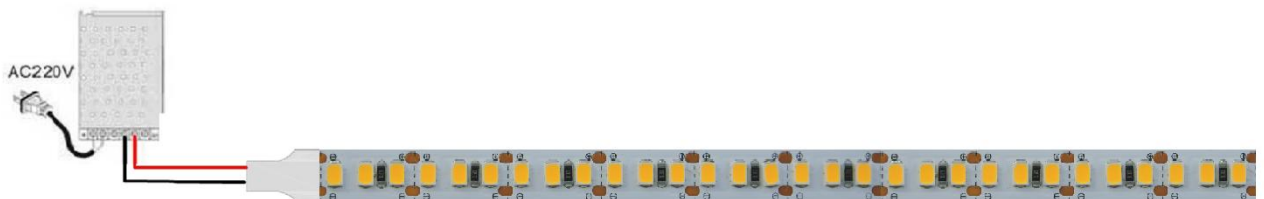

LINKING OPERATION

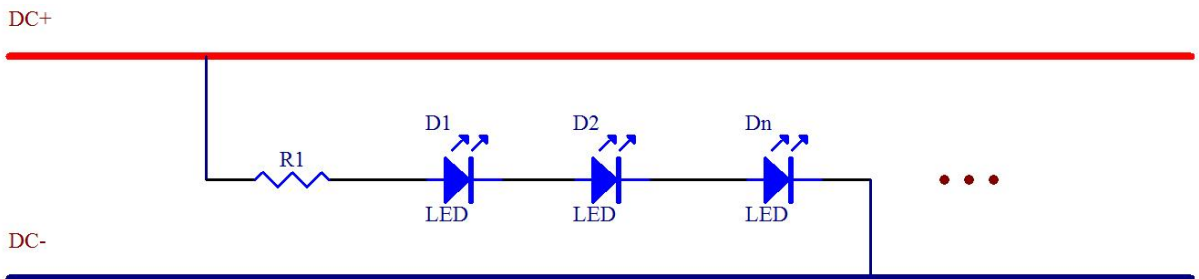

INSTALLATION

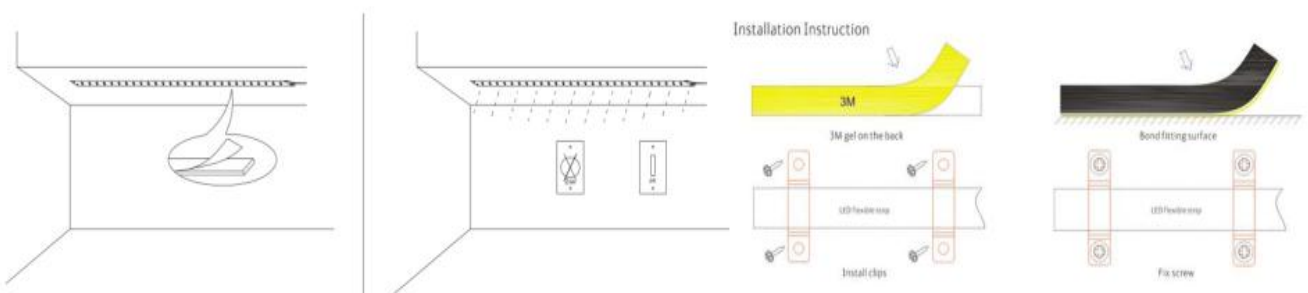

PRODUCT PACKAGING

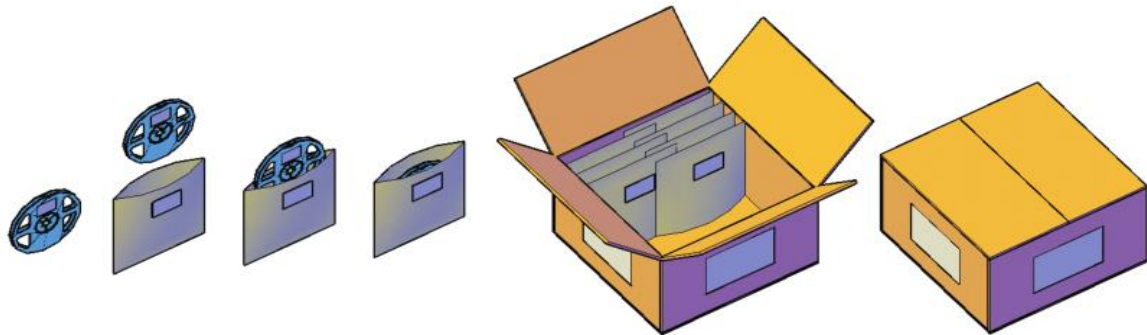

SAFETY INFORMATION

- The strip itself and all its components may not be mechanically stressed.
- Assembly must not damage or destroy conducting paths on the circuit board.
- Installation of LED ribbon (with power supplies) needs to be made with regard to all applicable electrical and safety standards. Only qualified personnel should be allowed to perform installations.
- Correct electrical polarity needs to be observed. Wrong polarity may destroy the strip.
- Parallel connection is highly recommended as safe electrical operation mode.
- Serial connection is not recommended. Unbalanced voltage drop can cause hazardous overload and damage the strip.
- Please ensure that the power supply is of adapters power to operate the total load.
- When mounting on metallic or otherwise conductive surfaces, there needs to be an electrical isolation points between strip and the mounting surface.
- Pay attention to standard ESD precautions when installing the strip.
- Damaged by corrosion will not be honored as a materials defect claim. It is the user's responsibility to provide suitable protection against corrosive agents such as moisture and condensation and other harmful elements.

LUXEON 2835 Architectural

Perfected performance, built on a proven legacy

LUXEON 2835 Architectural is a collection of compact devices that allows for design freedom and provides a superior overall system solution when a project requires high lumen output and good efficacy. With an industry standard footprint, the LUXEON 2835 Architectural is the perfect upgrade for other 2835 products and other common mid power offerings. LUXEON 2835 Architectural is color targeted for application needs and delivers efficacy and reliability for a variety of applications.



FEATURES AND BENEFITS

Various configurations of voltage and die count to meet a wide range of application requirements

Industry standard footprint for drop-in replacement designs

Maximum drive current of up to 480mA allows for reduction of LED count

6V and 9V hot-color targeting and 1/9th micro-color binning enable tight color control

2-, 3-, 4- and 5-step MacAdam ellipse color kits available

PRIMARY APPLICATIONS

Panel / Soft Lights

Linear

Troffers

Downlights

Retrofit Lamps

[More...](#)

Table of Contents

General Product Information	2
Product Test Conditions	2
Part Number Nomenclature	2
Lumen Maintenance	2
Environmental Compliance	2
Performance Characteristics	3
Product Selection Guide	3
Optical Characteristics	6
Electrical and Thermal Characteristics	6
Absolute Maximum Ratings	7
Characteristics Curves	8
Spectral Power Distribution Characteristics	8
Light Output Characteristics	12
Forward Current Characteristics	14
Radiation Pattern Characteristics	16
Product Bin and Labeling Definitions	17
Decoding Product Bin Labeling	17
Luminous Flux Bins	18
Color Bin Definition	20
Forward Voltage Bins	34
Mechanical Dimensions	35
Reflow Soldering Guidelines	36
JEDEC Moisture Sensitivity	36
Solder Pad Design	37
Packaging Information	37
Pocket Tape Dimensions	37
Reel Dimensions	38

General Product Information

Product Test Conditions

LUXEON 2835 Architectural LEDs are tested with a 20ms monopulse of driving current specified below at a junction temperature, T_j , of 25°C unless otherwise noted. Forward voltage and luminous flux are binned at a T_j of 25°C. LUXEON 2835E 6V, LUXEON 2835E 9V and LUXEON 2835C 6V color is hot-targeted at a T_j of 85°C and LUXEON 2835 HE 3V, LUXEON 2835N 3V, LUXEON 2835E 3V, LUXEON 2835C 3V and LUXEON 2835C 3V TVS color is cold-targeted at a T_j of 25°C.

60mA/100mA – LUXEON 2835E

120mA – LUXEON 2835C

65mA – LUXEON 2835 HE, LUXEON 2835N 3V

65mA (50ms) – LUXEON 2835 HE ended with 0Kx and associated parts

Part Number Nomenclature

Part numbers for LUXEON 2835 Architectural follow the convention below:

L 1 2 8 – **A A B B C D** 3 5 0 0 0 **E F**

Where:

- A A** – designates nominal ANSI CCT (18=1800K, 22=2200K, 27=2700K, 30=3000K, 35=3500K, 40=4000K, 50=5000K, 57=5700K, 65=6500K)
- B B** – designates minimum CRI (80=80CRI and 90=90CRI)
- C** – designates product line (E, C, N, H, etc)
- D** – designates voltage of the part (A=3V, B=6V and C=9V)
- E** – designates Lumileds internal code (B, H, T, K, etc)
- F** – designates Lumileds internal code (1, 2, 3, etc.=shares the same base part)

Therefore, the following part number is used for a LUXEON 2835C 3000K 80CRI, 6V LED:

L 1 2 8 – **3 0 8 0 C B** 3 5 0 0 0 **0 1**

Lumen Maintenance

Please contact your local Sales Representative or Lumileds Technical Solutions Manager for more information about the long-term performance of this product.

Environmental Compliance

Lumileds LLC is committed to providing environmentally friendly products to the solid-state lighting market. LUXEON 2835 Architectural is compliant to the European Union directives on the restriction of hazardous substances in electronic equipment, namely the RoHS Directive 2011/65/EU and REACH Regulation (EC) 1907/2006. Lumileds LLC will not intentionally add the following restricted materials to its products: lead, mercury, cadmium, hexavalent chromium, polybrominated biphenyls (PBB) or polybrominated diphenyl ethers (PBDE).

Performance Characteristics

Product Selection Guide

Table 1. Product performance of LUXEON 2835 Architectural at specified test conditions.

VOLTAGE	PART	NOMINAL CCT ^[1]	MINIMUM CRI ^[2, 3]	LUMINOUS FLUX ^[2, 3] (lm)		TYPICAL LUMINOUS EFFICACY (lm/W)	TEST CURRENT (mA)	PART NUMBER
				MINIMUM	TYPICAL			
3V	LUXEON 2835E	2700K	80	23.0	27.6	158.6	60	L128-2780EA3500001
		3000K	80	24.0	28.6	164.4	60	L128-3080EA3500001
		3500K	80	24.0	29.6	170.1	60	L128-3580EA3500001
		4000K	80	26.0	30.1	173.0	60	L128-4080EA3500001
		5000K	80	26.0	30.1	173.0	60	L128-5080EA3500001
		5700K	80	26.0	30.1	173.0	60	L128-5780EA3500001
		6500K	80	26.0	29.9	171.8	60	L128-6580EA3500001
		2700K	90	19.0	23.5	135.1	60	L128-2790EA3500001
		3000K	90	20.0	24.8	142.5	60	L128-3090EA3500001
		3500K	90	20.0	25.7	147.7	60	L128-3590EA3500001
		4000K	90	21.0	26.3	151.1	60	L128-4090EA3500001
		5000K	90	21.0	26.3	151.1	60	L128-5090EA3500001
		5700K	90	21.0	26.3	151.1	60	L128-5790EA3500001
		6500K	90	21.0	26.0	149.4	60	L128-6590EA3500001
		LUXEON 2835C	2700K	80	49.0	58.2	161.7	120
	3000K		80	51.0	60.2	167.2	120	L128-3080CA3500001
	3500K		80	53.0	61.2	170.0	120	L128-3580CA3500001
	4000K		80	55.0	63.8	177.2	120	L128-4080CA3500001
	5000K		80	55.0	63.8	177.2	120	L128-5080CA3500001
	5700K		80	55.0	63.8	177.2	120	L128-5780CA3500001
	6500K		80	55.0	63.8	177.2	120	L128-6580CA3500001
	2700K		90	42.0	49.8	138.3	120	L128-2790CA3500001
	3000K		90	42.0	51.9	144.2	120	L128-3090CA3500001
	3500K		90	44.0	53.5	148.6	120	L128-3590CA3500001
	4000K		90	46.0	54.6	151.7	120	L128-4090CA3500001
	5000K		90	46.0	54.6	151.7	120	L128-5090CA3500001
	5700K		90	46.0	54.6	151.7	120	L128-5790CA3500001
	6500K		90	46.0	54.6	151.7	120	L128-6590CA3500001
	LUXEON 2835N		1800K	80	21.9	23.3	130.3	65
		2200K	80	26.6	28.3	158.3	65	L128-2280NA3500001
2700K		80	30.3	32.5	181.8	65	L128-2780NA3500001	
3000K		80	32.3	34.4	192.4	65	L128-3080NA3500001	
3500K		80	33.7	35.9	200.8	65	L128-3580NA3500001	
4000K		80	34.3	36.5	204.2	65	L128-4080NA3500001	
5000K		80	34.3	36.5	204.2	65	L128-5080NA3500001	
5700K		80	34.3	36.5	204.2	65	L128-5780NA3500001	
6500K		80	33.7	35.9	200.8	65	L128-6580NA3500001	
1800K		90	18.0	19.1	106.9	65	L128-1890NA3500001	
2200K		90	23.1	24.6	137.6	65	L128-2290NA3500001	
2700K		90	26.2	27.9	156.1	65	L128-2790NA3500001	
3000K		90	27.3	29.0	162.2	65	L128-3090NA3500001	
3500K		90	28.4	30.2	169.0	65	L128-3590NA3500001	
4000K		90	29.3	31.2	174.5	65	L128-4090NA3500001	
5000K	90	29.3	31.2	174.5	65	L128-5090NA3500001		
5700K	90	29.3	31.2	174.5	65	L128-5790NA3500001		
6500K	90	29.1	31.0	173.4	65	L128-6590NA3500001		

Table 1 continued on next page.

- Correlated color temperature is cold-targeted at $T_j=25^\circ\text{C}$ for 3V products (LUXEON 2835 HE, LUXEON 2835N 3V, LUXEON 2835E 3V, LUXEON 2835C 3V, and LUXEON 2835C 3V TVS). Correlated color temperature is hot-targeted at $T_j=85^\circ\text{C}$ for 6V and 9V products (LUXEON 2835E 6V, LUXEON 2835E 9V, and LUXEON 2835C 6V).
- Luminous flux and CRI specs are based upon mounted package on highly reflective surface at $T_j=25^\circ\text{C}$. Typical CRI is approximately 2 points higher than the minimum CRI specified, but this is not guaranteed.
- Lumileds maintains a tolerance of ± 2 on CRI and $\pm 7.5\%$ on luminous flux measurements.

Table 1. Product performance of LUXEON 2835 Architectural at specified test conditions, continued.

VOLTAGE	PART	NOMINAL CCT ^[1]	MINIMUM CRI ^[2, 3]	LUMINOUS FLUX ^[2, 3] (lm)		TYPICAL LUMINOUS EFFICACY (lm/W)	TEST CURRENT (mA)	PART NUMBER
				MINIMUM	TYPICAL			
3V	LUXEON 2835 HE	3000K	70	32.4	37.1	210.6	65	L128-3070HA35000B1
		3500K	70	32.8	37.7	214.0	65	L128-3570HA35000B1
		4000K	70	34.0	38.6	219.1	65	L128-4070HA35000B1
		5000K	70	34.0	38.6	219.1	65	L128-5070HA35000B1
		5700K	70	33.7	38.1	216.3	65	L128-5770HA35000B1
		6500K	70	33.6	38.1	216.3	65	L128-6570HA35000B1
		1800K	80	22.1	23.5	133.4	65	L128-1880HA35000B1
		2200K	80	26.0	29.1	165.2	65	L128-2280HA35000B1
		2700K	80	30.5	34.0	193.0	65	L128-2780HA35000B1
		3000K	80	31.5	34.9	198.1	65	L128-3080HA35000B1
		3500K	80	32.7	36.4	206.6	65	L128-3580HA35000B1
		4000K	80	33.5	36.8	208.9	65	L128-4080HA35000B1
		5000K	80	33.5	36.8	208.9	65	L128-5080HA35000B1
		5700K	80	33.5	36.8	208.9	65	L128-5780HA35000B1
		6500K	80	33.0	36.5	207.2	65	L128-6580HA35000B1
		1800K	90	17.9	19.0	107.9	65	L128-1890HA35000B1
		2200K	90	22.9	24.4	138.5	65	L128-2290HA35000B1
		2700K	90	24.3	27.9	158.4	65	L128-2790HA35000B1
		3000K	90	25.4	29.5	167.5	65	L128-3090HA35000B1
		3500K	90	26.7	30.4	172.6	65	L128-3590HA35000B1
		4000K	90	27.4	31.0	176.0	65	L128-4090HA35000B1
		5000K	90	27.4	31.0	176.0	65	L128-5090HA35000B1
		5700K	90	27.4	31.0	176.0	65	L128-5790HA35000B1
		6500K	90	27.0	30.9	175.4	65	L128-6590HA35000B1
		2700K	95	23.4	27.2	154.4	65	L128-2795HA35000B1
		3000K	95	24.3	28.2	160.1	65	L128-3095HA35000B1
		3500K	95	24.7	28.5	161.5	65	L128-3595HA35000B1
		4000K	95	25.4	29.0	164.5	65	L128-4095HA35000B1
		5000K	95	25.9	29.6	168.0	65	L128-5095HA35000B1
		5700K	95	26.3	30.0	170.0	65	L128-5795HA35000B1
		2700K	70	35.5	37.4	212.3	65	L128-2770HA35000H1
		3000K	70	35.5	38.5	218.6	65	L128-3070HA35000H1
		3500K	70	36.1	38.8	220.3	65	L128-3570HA35000H1
		4000K	70	37.0	39.8	225.9	65	L128-4070HA35000H1
		5000K	70	37.0	39.8	225.9	65	L128-5070HA35000H1
		5700K	70	36.5	39.5	224.2	65	L128-5770HA35000H1
		6500K	70	36.5	39.5	224.2	65	L128-6570HA35000H1
		1800K	80	23.3	24.8	140.8	65	L128-1880HA35000H1
		2200K	80	28.7	30.5	173.1	65	L128-2280HA35000H1
		2700K	80	32.4	34.5	195.9	65	L128-2780HA35000H1
		3000K	80	33.4	35.5	201.5	65	L128-3080HA35000H1
		3500K	80	34.8	37.0	210.0	65	L128-3580HA35000H1
		4000K	80	35.8	38.1	216.3	65	L128-4080HA35000H1
		5000K	80	35.8	38.1	216.3	65	L128-5080HA35000H1
		5700K	80	35.3	37.5	212.9	65	L128-5780HA35000H1
6500K	80	34.8	37.0	210.0	65	L128-6580HA35000H1		
1800K	90	18.2	19.6	111.3	65	L128-1890HA35000H1		
2200K	90	23.4	25.3	143.6	65	L128-2290HA35000H1		
2700K	90	27.3	28.9	164.1	65	L128-2790HA35000H1		
3000K	90	28.9	30.4	172.6	65	L128-3090HA35000H1		
3500K	90	29.8	31.3	177.7	65	L128-3590HA35000H1		
4000K	90	30.4	31.9	181.1	65	L128-4090HA35000H1		
5000K	90	30.4	31.9	181.1	65	L128-5090HA35000H1		
5700K	90	30.4	31.9	181.1	65	L128-5790HA35000H1		
6500K	90	30.2	31.8	180.5	65	L128-6590HA35000H1		

Table 1 continued on next page.

1. Correlated color temperature is cold-targeted at T₁=25°C for 3V products (LUXEON 2835 HE, LUXEON 2835N 3V, LUXEON 2835E 3V, LUXEON 2835C 3V, and LUXEON 2835C 3V TVS). Correlated color temperature is hot-targeted at T₁=85°C for 6V and 9V products (LUXEON 2835E 6V, LUXEON 2835E 9V, and LUXEON 2835C 6V).
2. Luminous flux and CRI specs are based upon mounted package on highly reflective surface at T₁=25°C. Typical CRI is approximately 2 points higher than the minimum CRI specified, but this is not guaranteed.
3. Lumileds maintains a tolerance of ±2 on CRI and ±7.5% on luminous flux measurements.

Table 1. Product performance of LUXEON 2835 Architectural at specified test conditions, continued.

VOLTAGE	PART	NOMINAL CCT ^[1]	MINIMUM CRI ^[2, 3]	LUMINOUS FLUX ^[2, 3] (lm)		TYPICAL LUMINOUS EFFICACY (lm/W)	TEST CURRENT (mA)	PART NUMBER
				MINIMUM	TYPICAL			
3V	LUXEON 2835 HE	2700K	90	29.8	31.7	180.0	65	L128-2790HA35000K1
		3000K	90	31.4	33.4	189.6	65	L128-3090HA35000K1
		3500K	90	32.4	34.5	195.9	65	L128-3590HA35000K1
		4000K	90	33.0	35.0	198.7	65	L128-4090HA35000K1
		5000K	90	33.0	35.0	198.7	65	L128-5090HA35000K1
		5700K	90	33.0	35.0	198.7	65	L128-5790HA35000K1
	LUXEON 2835C TVS	6500K	90	33.0	35.0	198.7	65	L128-6590HA35000K1
		2700K	80	48.0	57.8	160.6	120	L128-2780CA35000T1
		3000K	80	50.0	60.5	168.1	120	L128-3080CA35000T1
		3500K	80	52.0	62.0	172.2	120	L128-3580CA35000T1
		4000K	80	54.0	63.0	175.0	120	L128-4080CA35000T1
		5000K	80	54.0	63.0	175.0	120	L128-5080CA35000T1
		5700K	80	54.0	63.0	175.0	120	L128-5780CA35000T1
		6500K	80	54.0	62.5	173.6	120	L128-6580CA35000T1
6V	LUXEON 2835E	2700K	80	45.0	54.0	145.2	60	L128-2780EB3500001
		3000K	80	46.0	55.0	147.8	60	L128-3080EB3500001
		3500K	80	47.0	56.0	150.5	60	L128-3580EB3500001
		4000K	80	49.0	59.0	158.6	60	L128-4080EB3500001
		5000K	80	49.0	59.0	158.6	60	L128-5080EB3500001
		5700K	80	49.0	59.0	158.6	60	L128-5780EB3500001
	LUXEON 2835C	6500K	80	49.0	59.0	158.6	60	L128-6580EB3500001
		2700K	80	93.0	115.0	159.7	120	L128-2780CB3500001
		3000K	80	96.0	118.0	163.9	120	L128-3080CB3500001
		3500K	80	99.0	122.0	169.4	120	L128-3580CB3500001
		4000K	80	103.0	125.0	173.6	120	L128-4080CB3500001
		5000K	80	103.0	125.0	173.6	120	L128-5080CB3500001
		5700K	80	103.0	125.0	173.6	120	L128-5780CB3500001
		6500K	80	103.0	124.0	172.2	120	L128-6580CB3500001
9V	LUXEON 2835E	2700K	90	78.0	96.0	133.3	120	L128-2790CB3500001
		3000K	90	81.0	99.0	137.5	120	L128-3090CB3500001
		3500K	90	83.0	102.0	141.7	120	L128-3590CB3500001
		4000K	90	87.0	106.0	147.2	120	L128-4090CB3500001
		5000K	90	87.0	106.0	147.2	120	L128-5090CB3500001
		5700K	90	87.0	106.0	147.2	120	L128-5790CB3500001
	LUXEON 2835C	6500K	90	87.0	106.0	147.2	120	L128-6590CB3500001
		6500K	70	78.0	93.0	174.2	60	L128-6570EC3500001
		2200K	80	59.0	70.0	131.1	60	L128-2280EC3500001
		2700K	80	67.0	81.0	151.7	60	L128-2780EC3500001
		3000K	80	70.0	85.0	159.2	60	L128-3080EC3500001
		3500K	80	72.0	88.0	164.8	60	L128-3580EC3500001
		4000K	80	74.0	90.0	168.5	60	L128-4080EC3500001
		5000K	80	74.0	90.0	168.5	60	L128-5080EC3500001
LUXEON 2835E	5700K	80	74.0	90.0	168.5	60	L128-5780EC3500001	
	6500K	80	74.0	89.0	166.7	60	L128-6580EC3500001	
	2200K	90	50.0	60.0	112.4	60	L128-2290EC3500001	
	2700K	90	54.0	68.0	127.3	60	L128-2790EC3500001	
	3000K	90	57.0	71.0	133.0	60	L128-3090EC3500001	
	3500K	90	60.0	74.0	138.6	60	L128-3590EC3500001	
	4000K	90	62.0	76.0	142.3	60	L128-4090EC3500001	
	5000K	90	62.0	76.0	142.3	60	L128-5090EC3500001	

Table 1 continued on next page.

1. Correlated color temperature is cold-targeted at T_c=25°C for 3V products (LUXEON 2835 HE, LUXEON 2835N 3V, LUXEON 2835E 3V, LUXEON 2835C 3V, and LUXEON 2835C 3V TVS). Correlated color temperature is hot-targeted at T_c=85°C for 6V and 9V products (LUXEON 2835E 6V, LUXEON 2835E 9V, and LUXEON 2835C 6V).
2. Luminous flux and CRI specs are based upon mounted package on highly reflective surface at T_c=25°C. Typical CRI is approximately 2 points higher than the minimum CRI specified, but this is not guaranteed.
3. Lumileds maintains a tolerance of ±2 on CRI and ±7.5% on luminous flux measurements.

Optical Characteristics

Table 2. Optical characteristics for LUXEON 2835 Architectural at specified test current, $T_j=25^{\circ}\text{C}$.

PART NUMBER	TYPICAL TOTAL INCLUDED ANGLE ^[1]	TYPICAL VIEWING ANGLE ^[2]
L128-xxxxx35000x1	160°	120°

Notes for Table 2:

1. Total angle at which 90% of total luminous flux is captured.
2. Viewing angle is the off axis angle from the LED centerline where the luminous intensity is ½ of the peak value.

Electrical and Thermal Characteristics

Table 3. Electrical and thermal characteristics for LUXEON 2835 Architectural at specified test current, $T_j=25^{\circ}\text{C}$.

PART NUMBER	FORWARD VOLTAGE ^[1] (V_f)			TYPICAL TEMPERATURE COEFFICIENT OF FORWARD VOLTAGE ^[2] (mV/°C)	TYPICAL THERMAL RESISTANCE—JUNCTION TO SOLDER PAD (°C/W)
	MINIMUM	TYPICAL	MAXIMUM		
L128-xxxxEC3500001	8.4	8.9	9.9	-3.0 to -6.0	15
L128-xxxxEB3500001	5.6	6.1	6.6	-2.0 to -4.0	20
L128-xxxxEA3500001	2.7	2.9	3.1	-1.0 to -2.0	39
L128-xxxxCB3500001	5.8	6.0	6.6	-2.0 to -4.0	18
L128-xxxxCA35000x1	2.9	3.0	3.2	-1.0 to -2.0	21
L128-xxxxNA35000x1	2.68	2.75	2.88	-1.0 to -2.0	14
L128-xxxxHA35000x1	2.66	2.71	2.76	-1.0 to -2.0	10

Notes for Table 3:

1. Lumileds maintains a tolerance of $\pm 0.1\text{V}$ on forward voltage measurements.
2. Measured between 25°C and 85°C .

Absolute Maximum Ratings

Table 4. Absolute maximum ratings for LUXEON 2835 Architectural.

PARAMETER	MAXIMUM PERFORMANCE
DC Forward Current ^[1, 2]	150mA for L128-xxxxEC35000x1 150mA for L128-xxxxEB3500001 150mA for L128-xxxxEA3500001 240mA for L128-xxxxCx35000x1 300mA for L128-xxxxNA35000x1 480mA for L128-xxxxHA35000x1
Peak Pulsed Forward Current ^[1, 3]	200mA for L128-xxxxEx35000x1 300mA for L128-xxxxCx35000x1 450mA for L128-xxxxNA35000x1 600mA for L128-xxxxHA35000x1
LED Junction Temperature ^[1] (DC & Pulse)	125°C for L128-xxxxEC35000x1 125°C for L128-xxxxEB3500001 115°C for L128-xxxxEA3500001 125°C for L128-xxxxCx35000x1 125°C for L128-xxxxNA35000x1 125°C for L128-xxxxHA35000x1
ESD Sensitivity (ANSI/ESDA/JEDEC JS-001-2012)	Class 3B for LUXEON 2835C 3V TVS with ESD protection Class 2 for all other LUXEON 2835 parts
Operating Case Temperature ^[1]	-40°C to 105°C
LED Storage Temperature	-40°C to 105°C
Soldering Temperature	JEDEC 020c 260°C
Allowable Reflow Cycles	3
Reverse Voltage ^[4, 5] ($V_{reverse}$)	5

Notes for Table 4:

- Proper current derating must be observed to maintain the junction temperature below the maximum allowable junction temperature.
- Residual periodic variations due to power conversion from alternating current (AC) to direct current (DC), also called "ripple," are acceptable if the following conditions are met:
 - The frequency of the ripple current is 100Hz or higher
 - The average current for each cycle does not exceed the maximum allowable DC forward current
 - The maximum amplitude of the ripple does not exceed the maximum peak pulsed forward current
- At ≤50% duty cycle with pulse width of 5ms.
- Transient reverse voltages and surge currents due to electrical switching or supply interruptions are acceptable if these events do not last for more than 10ms, the amplitude of the reverse voltage does not exceed 5V and the reverse current is less than 220uA.
- Max 5V reverse for up to 10s is an acceptable beginning of life, one time test condition.

Characteristics Curves

Spectral Power Distribution Characteristics

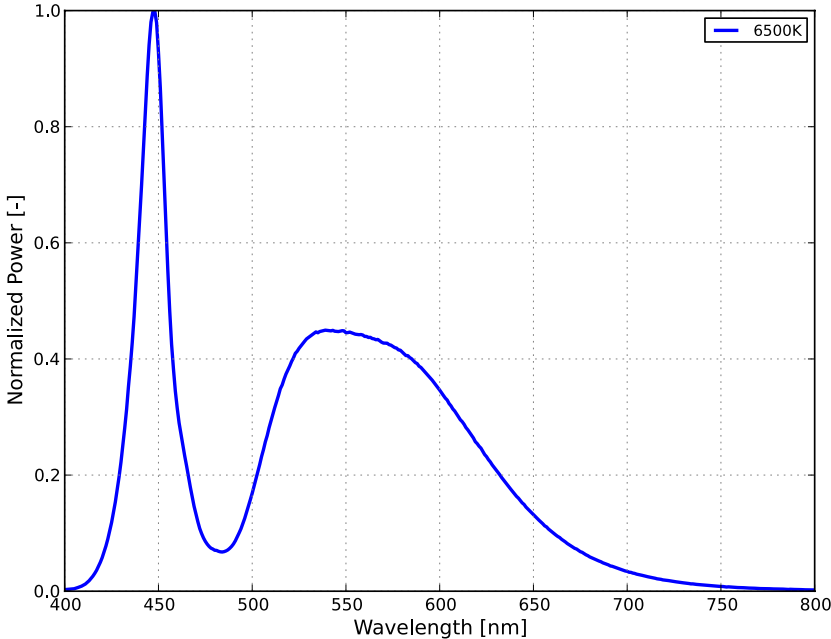

Figure 1a. Typical normalized power vs. wavelength for 70CRI LUXEON 2835E and LUXEON 2835C at specified test current, $T_j=25^{\circ}\text{C}$.

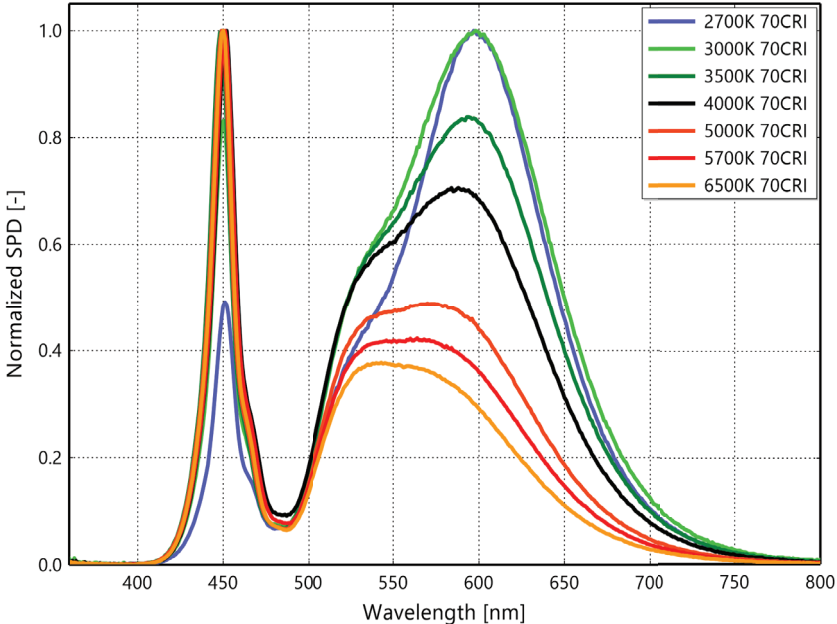

Figure 1b. Typical normalized SPD vs. wavelength for 70CRI LUXEON 2835 HE at specified test current, $T_j=25^{\circ}\text{C}$.

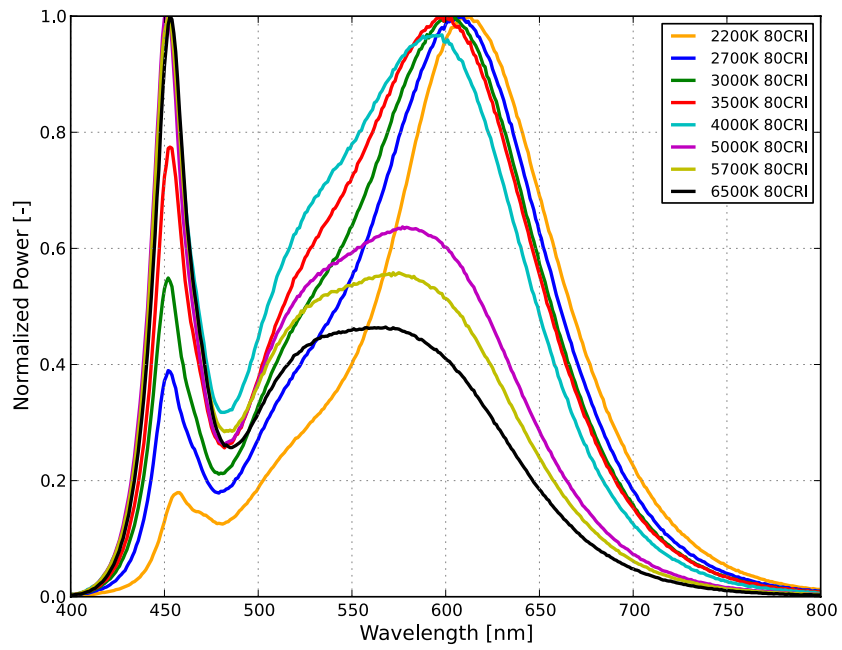

Figure 1c. Typical normalized power vs. wavelength for 80CRI LUXEON 2835E and LUXEON 2835C at specified test current, $T_j=25^\circ\text{C}$.

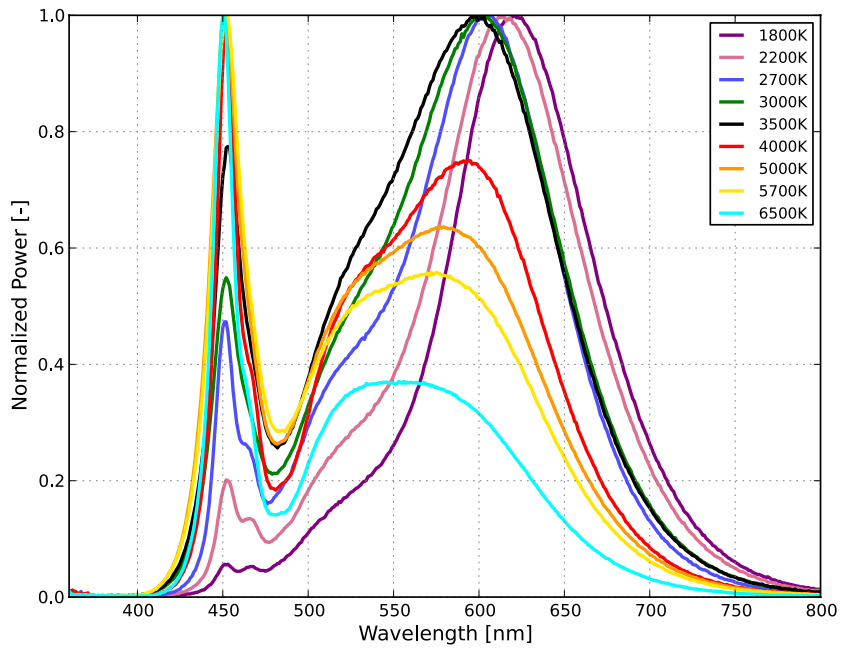

Figure 1d. Typical normalized power vs. wavelength for 80CRI LUXEON 2835 HE and LUXEON 2835N 3V at specified test current, $T_j=25^\circ\text{C}$.

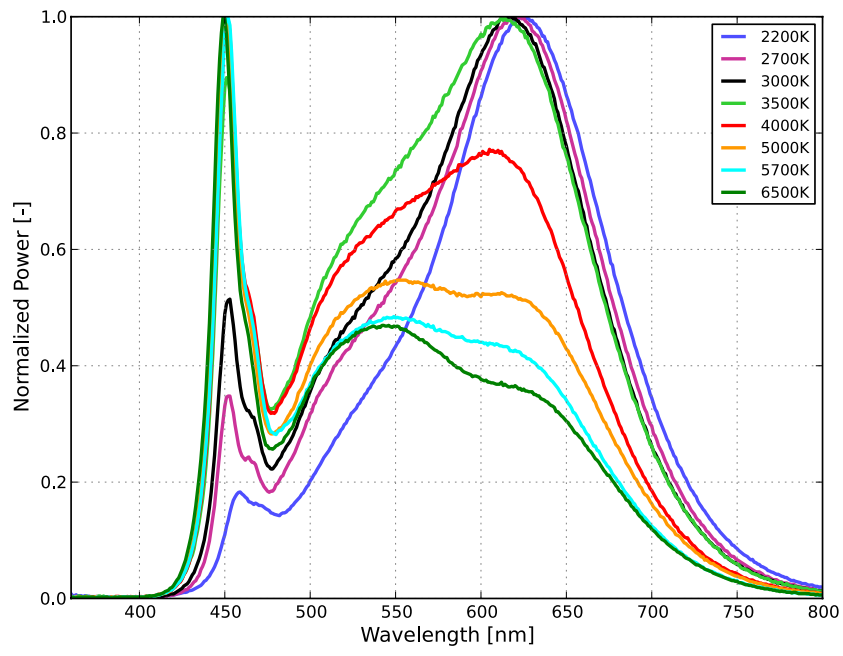

Figure 1e. Typical normalized power vs. wavelength for 90CRI LUXEON 2835E and LUXEON 2835C at specified test current, $T_j=25^{\circ}\text{C}$.

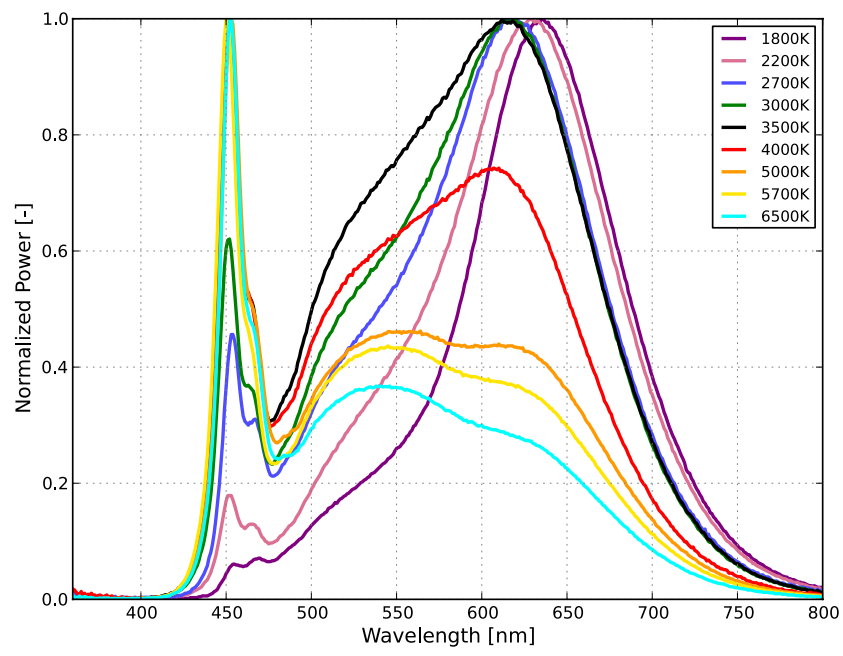

Figure 1f. Typical normalized power vs. wavelength for 90CRI LUXEON 2835 HE and LUXEON 2835N 3V at specified test current, $T_j=25^{\circ}\text{C}$.

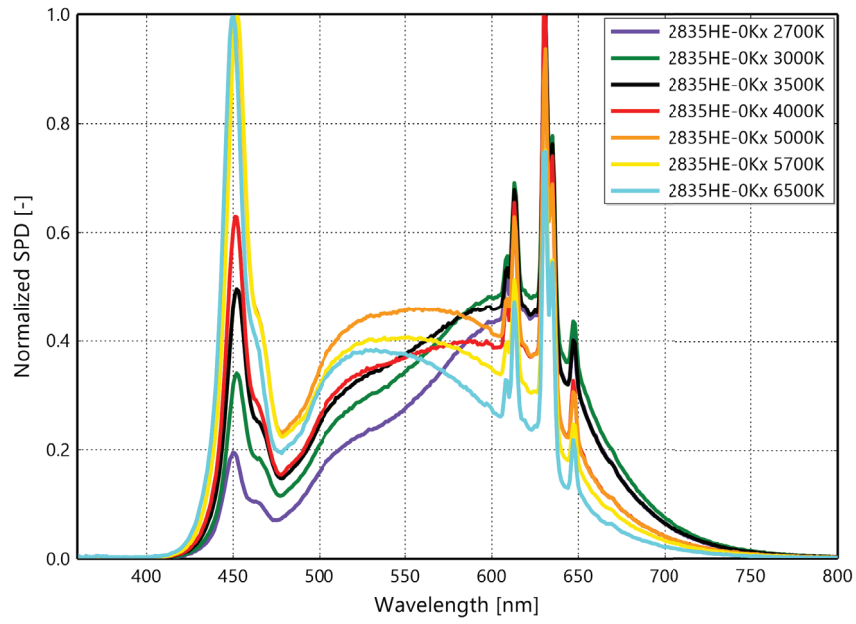

Figure 1g. Typical normalized SPD vs. wavelength for 90CRI LUXEON 2835 HE ended with 0Kx and associated parts at specified test current, $T_j=25^\circ\text{C}$.

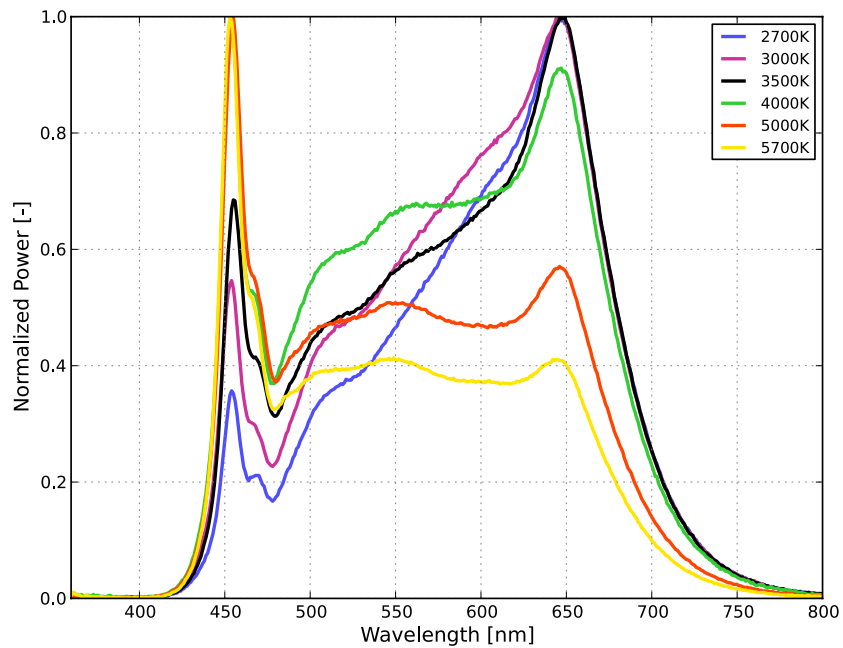

Figure 1h. Typical normalized power vs. wavelength for 95CRI LUXEON 2835 HE at specified test current, $T_j=25^\circ\text{C}$.

Light Output Characteristics

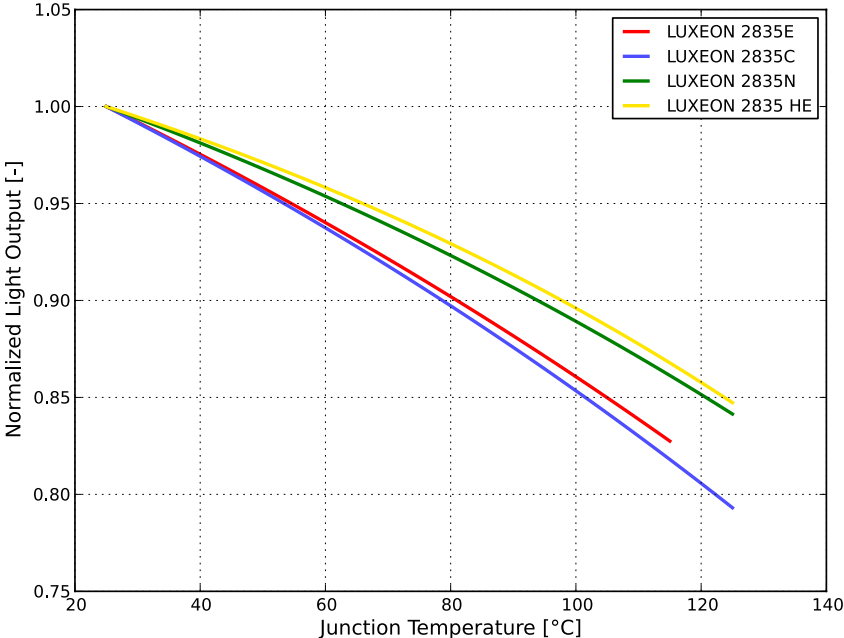

Figure 2. Typical normalized light output vs. junction temperature for LUXEON 2835 Architectural at specified test current.

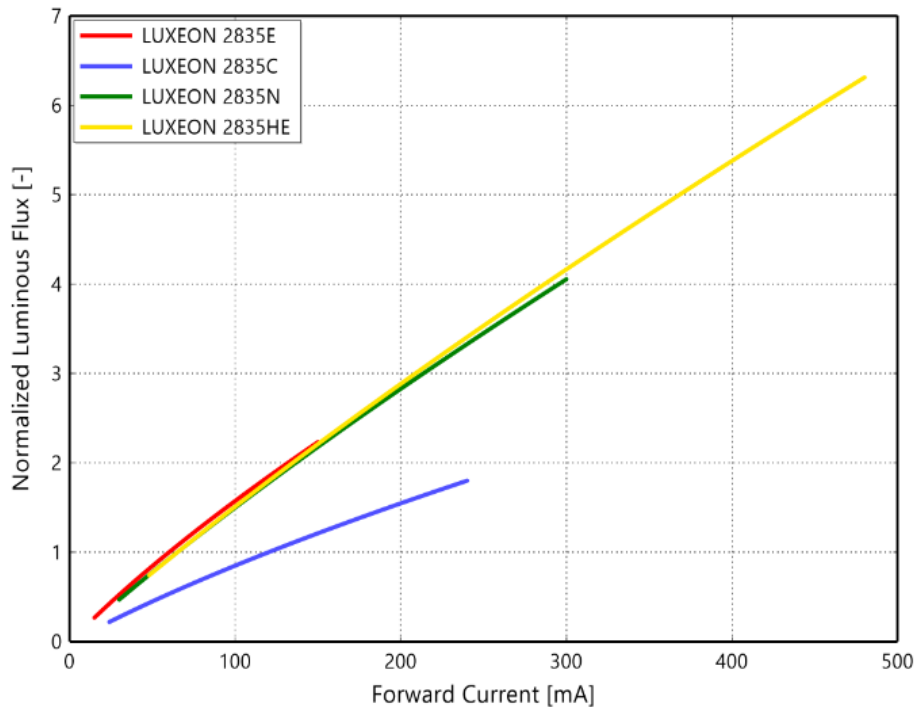

Figure 3. Typical normalized light output vs. forward current for LUXEON 2835 Architectural at $T_j=25^\circ\text{C}$.

LUXEON 2835E estimated typical ratio compared to flux at rated condition 60mA, $T_j=25^\circ\text{C}$.

PRODUCT	30mA	50mA	80mA	100mA	120mA
2835E 3V	53%	85%	129%	158%	185%
2835E 6V	53%	85%	129%	156%	182%
2835E 9V	53%	85%	129%	157%	183%

LUXEON 2835C estimated typical ratio compared to flux at rated condition 120mA, $T_j=25^\circ\text{C}$.

PRODUCT	50mA	65mA	100mA	150mA	200mA
2835C 3V	44%	56%	85%	123%	159%
2835C 6V	44%	56%	84%	123%	158%

LUXEON 2835 HE estimated typical ratio compared to flux at rated condition 65mA, $T_j=25^\circ\text{C}$.

PRODUCT	30mA	65mA	100mA	150mA	200mA
2835 HE	47%	100%	152%	223%	292%

LUXEON 2835N 3V estimated typical ratio compared to flux at rated condition 65mA, $T_j=25^\circ\text{C}$.

PRODUCT	30mA	65mA	100mA	150mA	200mA
2835N 3V	46%	100%	150%	220%	285%

Forward Current Characteristics

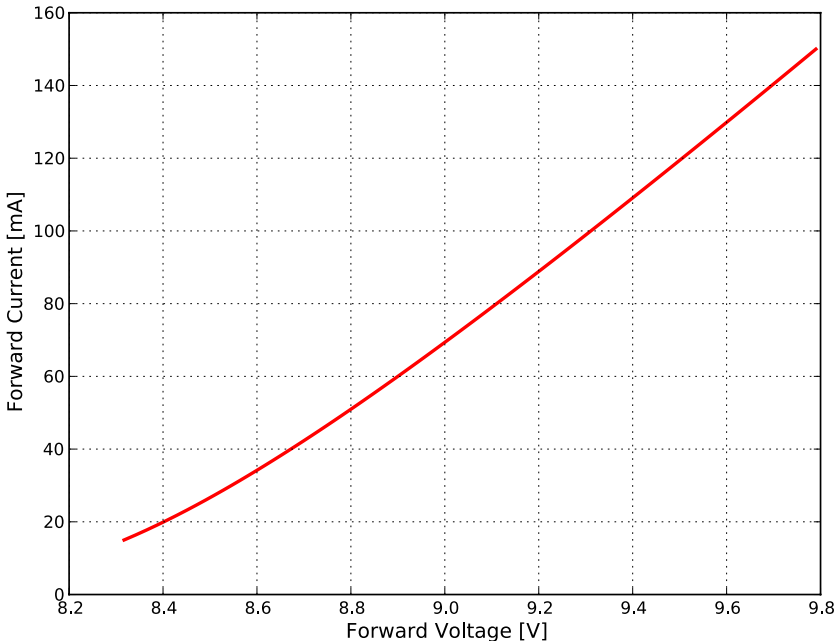

Figure 4a. Typical forward current vs. forward voltage for LUXEON 2835E 9V at $T_j=25^\circ\text{C}$.

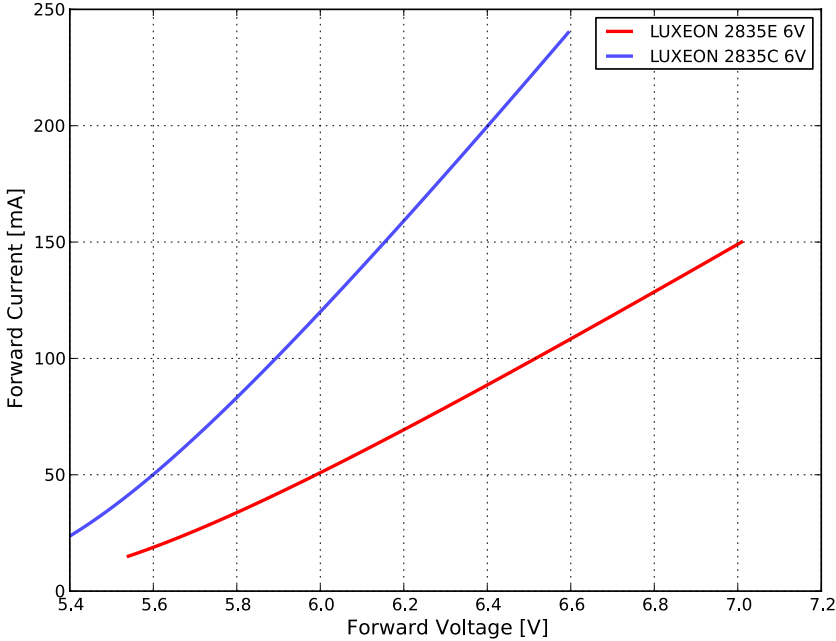

Figure 4b. Typical forward current vs. forward voltage for LUXEON 2835E 6V and LUXEON 2835C 6V at $T_j=25^\circ\text{C}$.

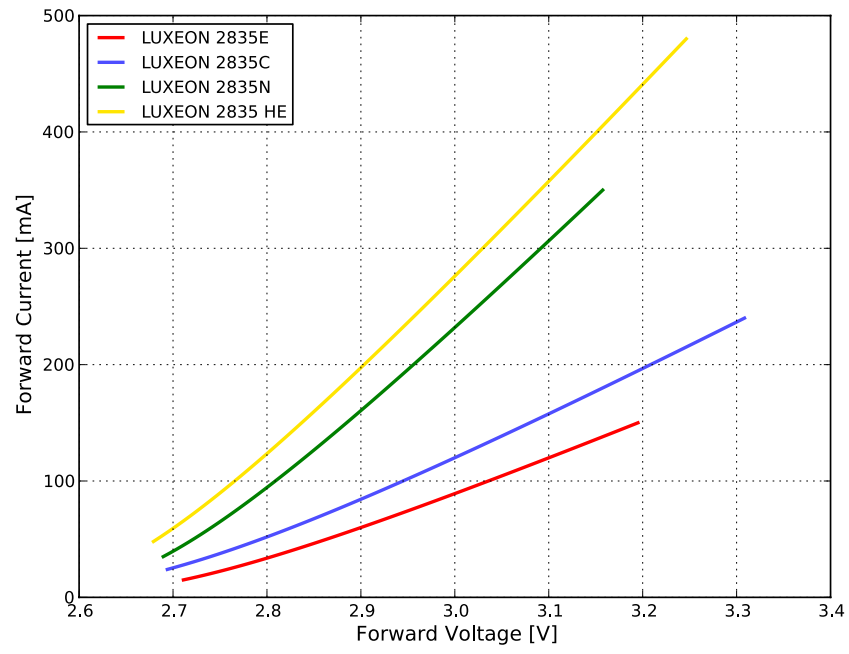

Figure 4c. Typical forward current vs. forward voltage for LUXEON 2835C Line 3V at $T_j=25^\circ\text{C}$.

Radiation Pattern Characteristics

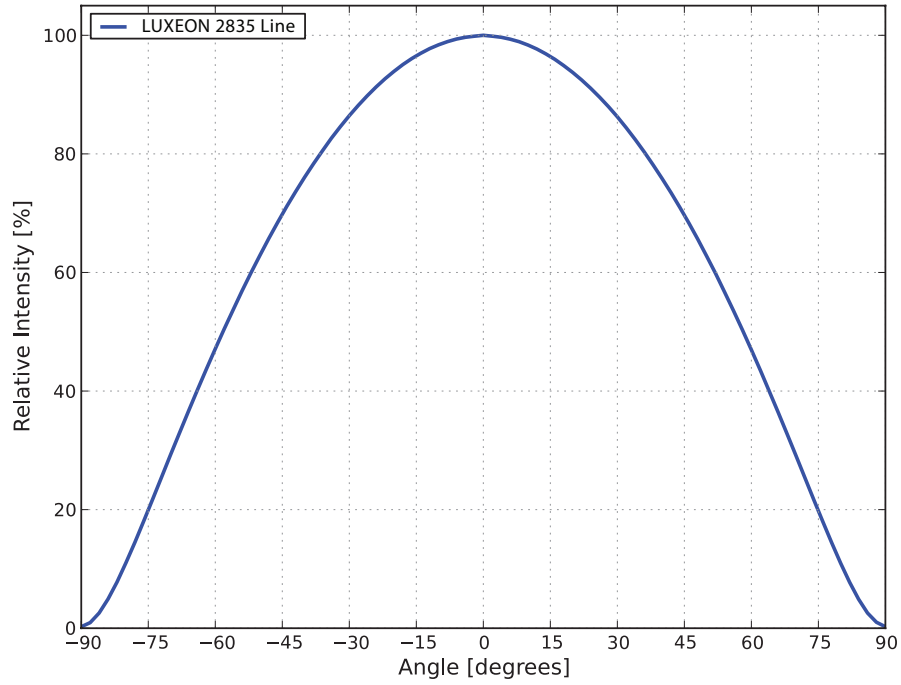

Figure 5. Typical radiation pattern for LUXEON 2835 Architectural at test current, $T_j=25^{\circ}\text{C}$.

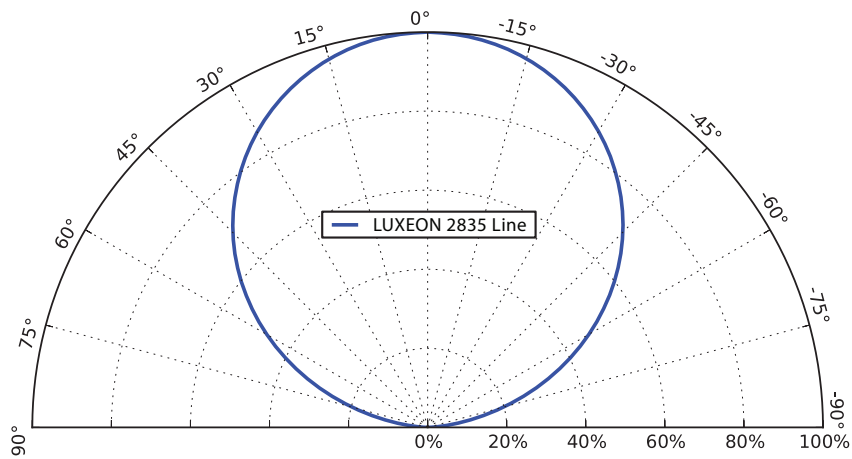

Figure 6. Typical polar radiation pattern for LUXEON 2835 Architectural at test current, $T_j=25^{\circ}\text{C}$.

Product Bin and Labeling Definitions

Decoding Product Bin Labeling

In the manufacturing of semiconductor products, there are variations in performance around the average values given in the technical datasheet. For this reason, Lumileds bins LED components for luminous flux or radiometric power, color point, peak or dominant wavelength and forward voltage.

LUXEON 2835 Architectural LEDs are labeled using a 4- or 5-digit alphanumeric CAT code following the format below:

A or Ax B C D

Where:

A or Ax – designates luminous flux bin (example: T=56 to 60 lm, D2=29 to 31 lm)

B C – designates correlated color bin (example: 5D, 5E, 5F, 5G, 5H, 5J, 5K, 5L, 5M for 4000K parts)

D – designates forward voltage bin (example: W=3.0 to 3.1V, X=3.1 to 3.2V)

Therefore, a LUXEON 2835C 3V LED with a lumen range of 56 to 60 lm, color bin of 5D and a forward voltage range of 3.0 to 3.1V has the following CAT code:

T 5 D W

Luminous Flux Bins

Table 5 lists the standard luminous flux bins for LUXEON 2835 Architectural emitters. Although several bins are outlined, product availability in a particular bin varies by production run and by product performance. Not all bins are available in all CCTs.

Table 5. Luminous flux bin definitions for LUXEON 2835 Architectural, $T_j=25^\circ\text{C}$.

PART	BIN	LUMINOUS FLUX ⁽¹⁾ (lm)	
		MINIMUM	MAXIMUM
LUXEON 2835E 9V LUXEON 2835C 6V	Z	50	55
	A	55	60
	B	60	65
	C	65	70
	D	70	75
	E	75	80
	F	80	85
	G	85	90
	H	90	95
	J	95	100
	K	100	105
	L	105	110
	M	110	115
	N	115	120
	P	120	125
	Q	125	130
	R	130	135
S	135	140	
T	140	145	
U	145	150	
LUXEON 2835E 3V	B1	19	21
	B2	21	23
	C1	23	25
	C2	25	27
	D1	27	29
	D2	29	31
	E1	31	33
LUXEON 2835C 3V LUXEON 2835C 3V TVS	P	40	44
	Q	44	48
	R	48	52
	S	52	56
	T	56	60
	U	60	63
	V	63	66
	W	66	69
	X	69	72
	Y	72	75

Table 5 continued on next page:

1. Lumileds maintains a tolerance of $\pm 7.5\%$ on luminous flux measurements.

Table 5. Luminous flux bin definitions for LUXEON 2835 Architectural, $T_j=25^\circ\text{C}$ (continued).

PART	BIN	LUMINOUS FLUX ⁽¹⁾ (lm)	
		MINIMUM	MAXIMUM
LUXEON 2835E 6V	P	40	44
	Q	44	48
	R	48	52
	S	52	56
	T	56	60
	U	60	65
	V	65	70
	W	70	75
LUXEON 2835 HE 3V LUXEON 2835N 3V	T	17.5	19.0
	U	19.0	20.5
	V	20.5	22.0
	W	22.0	23.5
	X	23.5	25.0
	Y	25.0	26.5
	Z	26.5	28.0
	A	28.0	29.5
	B	29.5	31.0
	C	31.0	32.5
	D	32.5	34.0
	E	34.0	35.5
	F	35.5	37.0
G	37.0	38.5	
H	38.5	40.0	
J	40.0	41.5	
K	41.5	43.0	

Notes for Table 5:

1. Lumileds maintains a tolerance of $\pm 7.5\%$ on luminous flux measurements.

Color Bin Definition

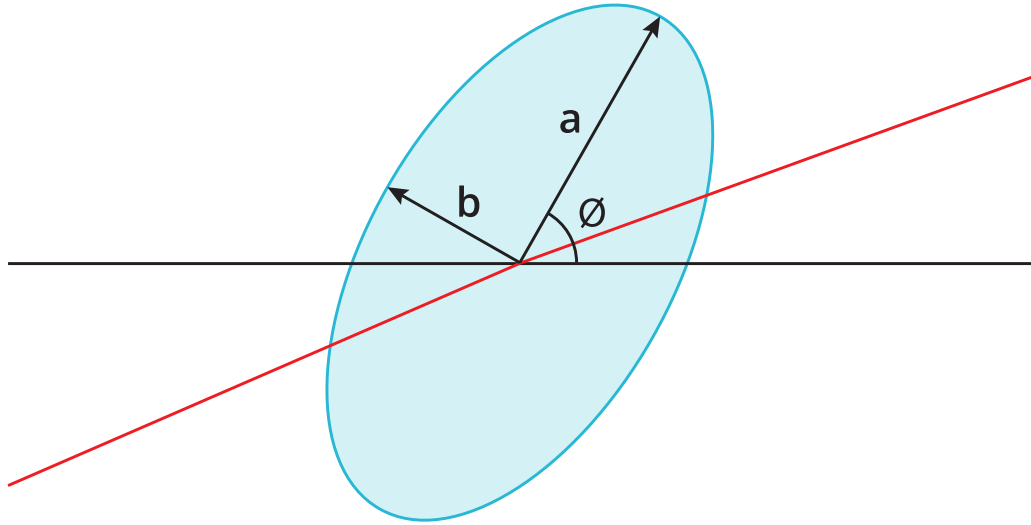

Figure 7. 3- and 5-step MacAdam ellipse illustration for Tables 6a–6h.

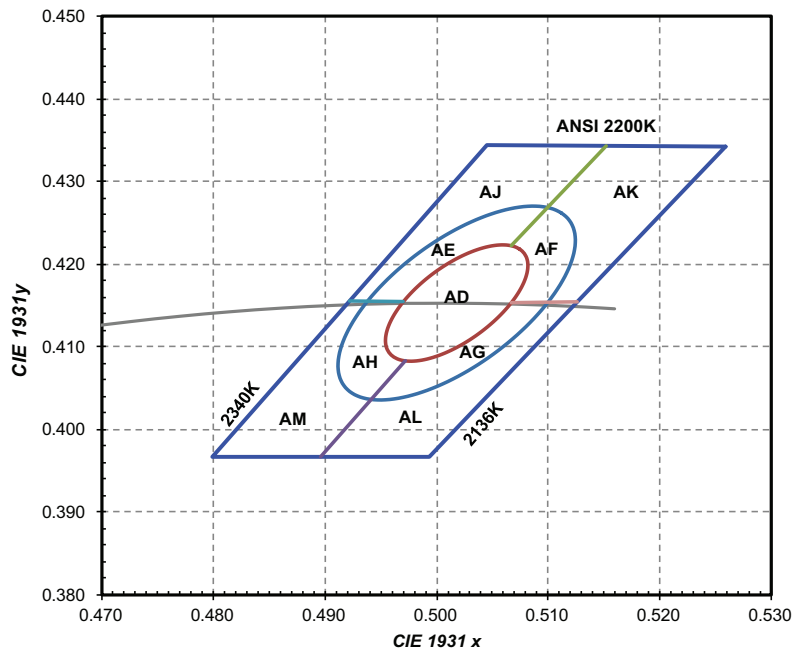

Figure 8a. 1/9th color bin structure for LUXEON 2835E and LUXEON 2835C 2200K at specified test current and binning temperatures of $T_j=25^\circ\text{C}$ and $T_j=85^\circ\text{C}$.

Table 6a. 3- and 5-step MacAdam ellipse color bin definitions for LUXEON 2835E and LUXEON 2835C 2200K, at specified test and binning conditions.

NOMINAL CCT	COLOR SPACE	CENTER POINT ^[1] (cx, cy)	MAJOR AXIS, a	MINOR AXIS, b	ELLIPSE ROTATION ANGLE, Ø
2200K	Single 3-step MacAdam ellipse	(0.5018, 0.4153)	0.00863	0.00398	49.27°
2200K	Single 5-step MacAdam ellipse	(0.5018, 0.4153)	0.01438	0.00663	49.27°

Notes for Table 6a:

1. Lumileds maintains a tolerance of ± 0.007 on x and y color coordinates in the CIE 1931 color space.

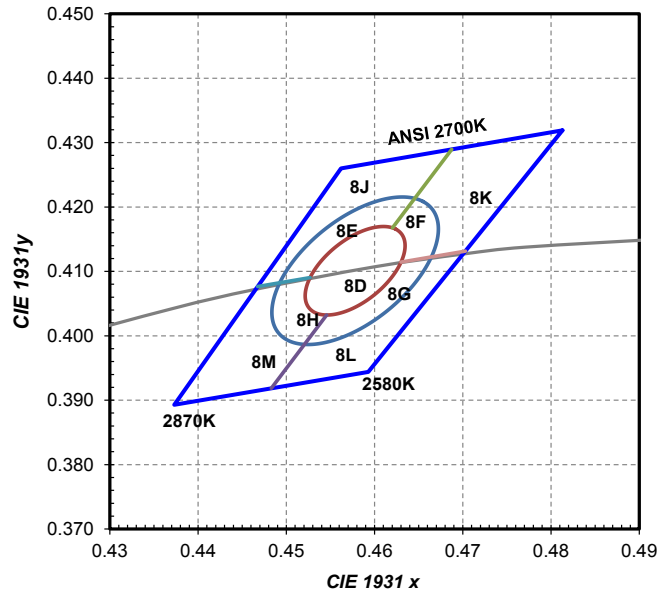

Figure 8b. 1/9th color bin structure for LUXEON 2835E and LUXEON 2835C 2700K at specified test current and binning temperatures of $T_j=25^{\circ}\text{C}$ and $T_j=85^{\circ}\text{C}$.

Table 6b. 3- and 5-step MacAdam ellipse color bin definitions for LUXEON 2835E and LUXEON 2835C 2700K, at specified test and binning conditions.

NOMINAL CCT	COLOR SPACE	CENTER POINT ^[1] (cx, cy)	MAJOR AXIS, a	MINOR AXIS, b	ELLIPSE ROTATION ANGLE, θ
2700K	Single 3-step MacAdam ellipse	(0.4578, 0.4101)	0.00810	0.00420	53.70°
2700K	Single 5-step MacAdam ellipse	(0.4578, 0.4101)	0.01350	0.00700	53.70°

Notes for Table 6b:

1. Lumileds maintains a tolerance of ± 0.007 on x and y color coordinates in the CIE 1931 color space.

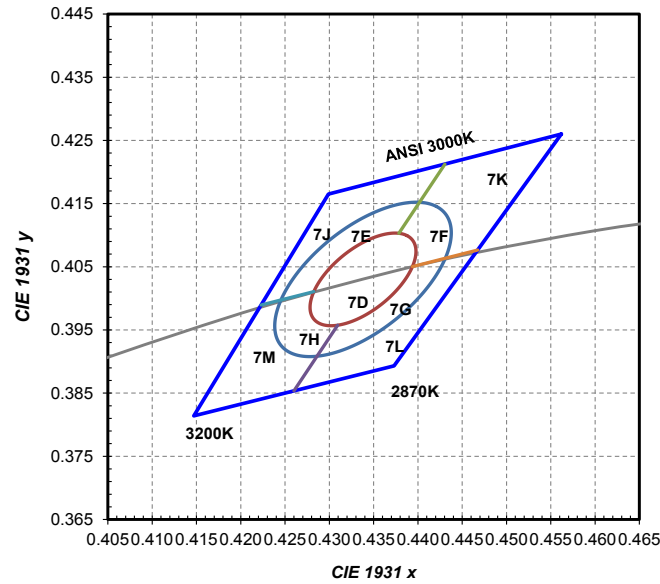

Figure 8c. 1/9th color bin structure for LUXEON 2835E and LUXEON 2835C 3000K at specified test current and binning temperatures of $T_j=25^{\circ}\text{C}$ and $T_j=85^{\circ}\text{C}$.

Table 6c. 3- and 5-step MacAdam ellipse color bin definitions for LUXEON 2835E and LUXEON 2835C 3000K, at at specified test and binning conditions.

NOMINAL CCT	COLOR SPACE	CENTER POINT ^[1] (cx, cy)	MAJOR AXIS, a	MINOR AXIS, b	ELLIPSE ROTATION ANGLE, θ
3000K	Single 3-step MacAdam ellipse	(0.4338, 0.4030)	0.00834	0.00408	53.22°
3000K	Single 5-step MacAdam ellipse	(0.4338, 0.4030)	0.01390	0.00680	53.22°

Notes for Table 6c:

1. Lumileds maintains a tolerance of ± 0.007 on x and y color coordinates in the CIE 1931 color space.

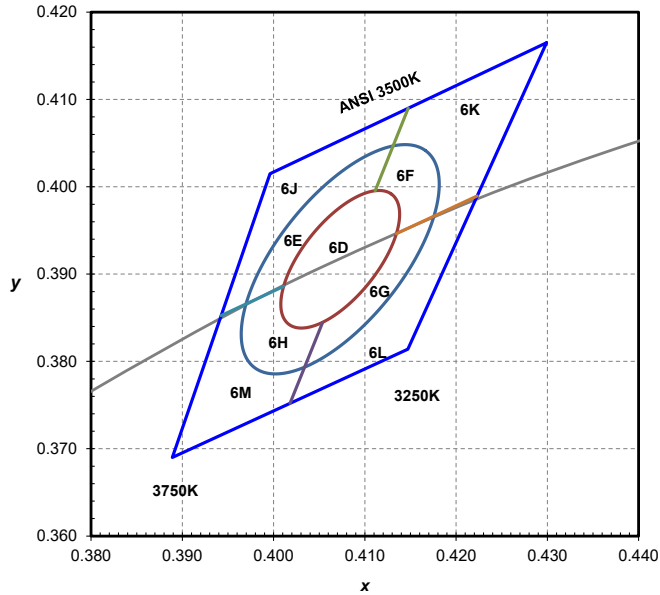

Figure 8d. 1/9th color bin structure for LUXEON 2835E and LUXEON 2835C 3500K at specified test current and binning temperatures of $T_j=25^{\circ}\text{C}$ and $T_j=85^{\circ}\text{C}$.

Table 6d. 3- and 5-step MacAdam ellipse color bin definitions for LUXEON 2835E and LUXEON 2835C 3500K, at specified test and binning conditions.

NOMINAL CCT	COLOR SPACE	CENTER POINT ⁽¹⁾ (cx, cy)	MAJOR AXIS, a	MINOR AXIS, b	ELLIPSE ROTATION ANGLE, θ
3500K	Single 3-step MacAdam ellipse	(0.4073, 0.3917)	0.00927	0.00414	54.00°
3500K	Single 5-step MacAdam ellipse	(0.4073, 0.3917)	0.01545	0.00690	54.00°

Notes for Table 6d:

1. Lumileds maintains a tolerance of ± 0.007 on x and y color coordinates in the CIE 1931 color space.

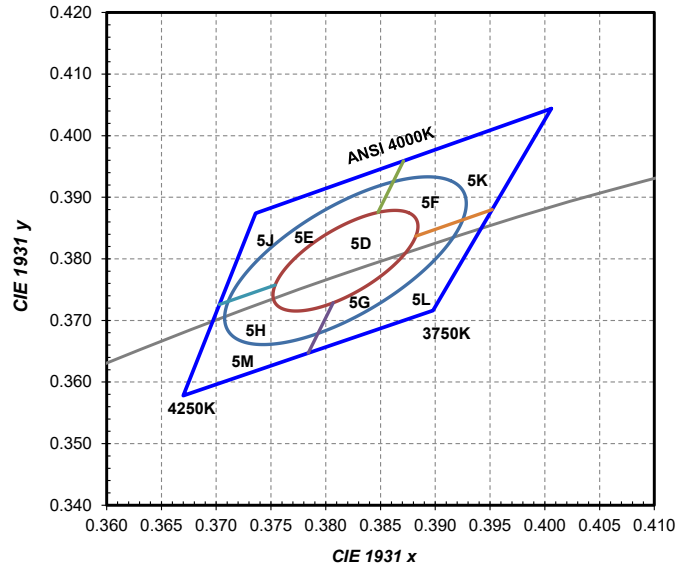

Figure 8e. 1/9th color bin structure for LUXEON 2835E and LUXEON 2835C 4000K at specified test current and binning temperatures of $T_j=25^{\circ}\text{C}$ and $T_j=85^{\circ}\text{C}$.

Table 6e. 3- and 5-step MacAdam ellipse color bin definitions for LUXEON 2835E and LUXEON 2835C 4000K, at specified test and binning conditions.

NOMINAL CCT	COLOR SPACE	CENTER POINT ⁽¹⁾ (cx, cy)	MAJOR AXIS, a	MINOR AXIS, b	ELLIPSE ROTATION ANGLE, θ
4000K	Single 3-step MacAdam ellipse	(0.3818, 0.3797)	0.00939	0.00402	53.72°
4000K	Single 5-step MacAdam ellipse	(0.3818, 0.3797)	0.01565	0.00670	53.72°

Notes for Table 6e:

1. Lumileds maintains a tolerance of ± 0.007 on x and y color coordinates in the CIE 1931 color space.

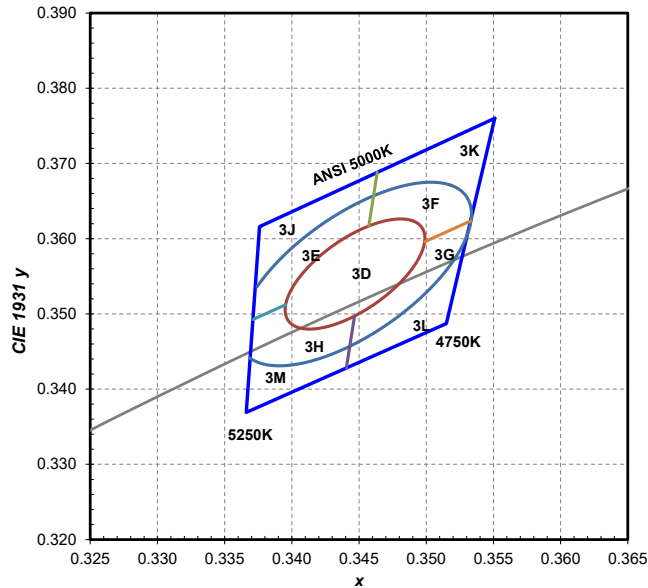

Figure 8f. 1/9th color bin structure for LUXEON 2835E and LUXEON 2835C 5000K at specified test current and binning temperatures of $T_j=25^{\circ}\text{C}$ and $T_j=85^{\circ}\text{C}$.

Table 6f. 3- and 5-step MacAdam ellipse color bin definitions for LUXEON 2835E and LUXEON 2835C 5000K, at specified test and binning conditions.

NOMINAL CCT	COLOR SPACE	CENTER POINT ^[1] (cx, cy)	MAJOR AXIS, a	MINOR AXIS, b	ELLIPSE ROTATION ANGLE, θ
5000K	Single 3-step MacAdam ellipse	(0.3447, 0.3553)	0.00822	0.00354	59.62°
5000K	Single 5-step MacAdam ellipse	(0.3447, 0.3553)	0.01370	0.00590	59.62°

Notes for Table 6f:

1. Lumileds maintains a tolerance of ± 0.007 on x and y color coordinates in the CIE 1931 color space.

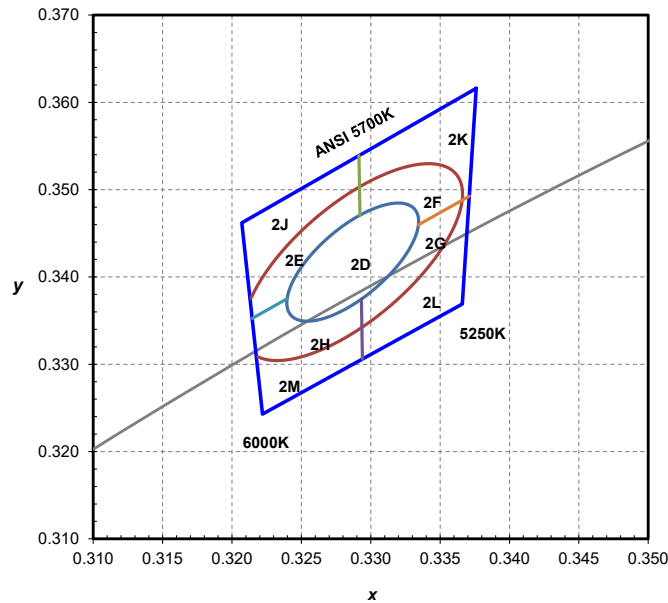

Figure 8g. 1/9th color bin structure for LUXEON 2835E and LUXEON 2835C 5700K at specified test current and binning temperatures of $T_j=25^{\circ}\text{C}$ and $T_j=85^{\circ}\text{C}$.

Table 6g. 3- and 5-step MacAdam ellipse color bin definitions for LUXEON 2835E and LUXEON 2835C 5700K, at specified test and binning conditions.

NOMINAL CCT	COLOR SPACE	CENTER POINT ^[1] (cx, cy)	MAJOR AXIS, a	MINOR AXIS, b	ELLIPSE ROTATION ANGLE, θ
5700K	Single 3-step MacAdam ellipse	(0.3287, 0.3417)	0.00746	0.00320	59.09°
5700K	Single 5-step MacAdam ellipse	(0.3287, 0.3417)	0.01243	0.00533	59.09°

Notes for Table 6g:

1. Lumileds maintains a tolerance of ± 0.007 on x and y color coordinates in the CIE 1931 color space.

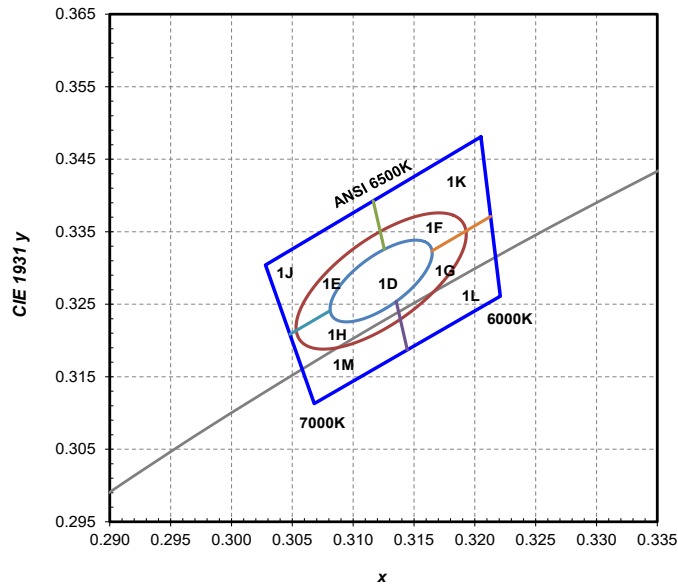

Figure 8h. 1/9th color bin structure for LUXEON 2835E and LUXEON 2835C 6500K at specified test current and binning temperatures of $T_j=25^{\circ}\text{C}$ and $T_j=85^{\circ}\text{C}$.

Table 6h. 3- and 5-step MacAdam ellipse color bin definitions for LUXEON 2835E and LUXEON 2835C 6500K, at specified test and binning conditions.

NOMINAL CCT	COLOR SPACE	CENTER POINT ⁽¹⁾ (cx, cy)	MAJOR AXIS, a	MINOR AXIS, b	ELLIPSE ROTATION ANGLE, θ
6500K	Single 3-step MacAdam ellipse	(0.3123, 0.3282)	0.00669	0.00285	58.57°
6500K	Single 5-step MacAdam ellipse	(0.3123, 0.3282)	0.01115	0.00475	58.57°

Notes for Table 6h:

1. Lumileds maintains a tolerance of ± 0.007 on x and y color coordinates in the CIE 1931 color space.

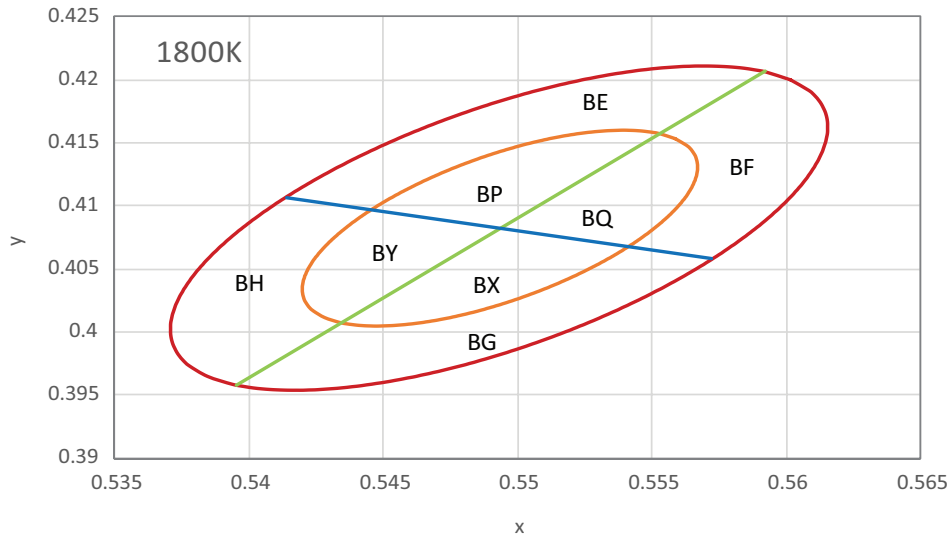

Figure 8i. 1/8th color bin structure for LUXEON 2835 HE and LUXEON 2835N 3V 1800K at specified test current and binning temperature of $T_j=25^{\circ}\text{C}$.

Table 6i-1. 3- and 5-step MacAdam ellipse color bin definitions for LUXEON 2835 HE and LUXEON 2835N 3V 1800K, at specified test and binning conditions.

NOMINAL CCT	COLOR SPACE	CENTER POINT ⁽¹⁾ (cx, cy)	MAJOR AXIS, a	MINOR AXIS, b	ELLIPSE ROTATION ANGLE, θ
1800K	Single 3-step MacAdam ellipse	(0.5493, 0.4083)	0.00962	0.00462	47.34°
1800K	Single 5-step MacAdam ellipse	(0.5493, 0.4083)	0.01603	0.00770	47.34°

Table 6i-2. 4 quadrants definition for LUXEON 2835 HE and LUXEON 2835N 3V 1800K, at specified test and binning conditions.

POINT	x	y
1	0.5592	0.4207
2	0.5414	0.4107
3	0.5395	0.3958
4	0.5572	0.4058
Center	0.5493	0.4083

Notes for Table 6i:

1. Lumileds maintains a tolerance of ± 0.007 on x and y color coordinates in the CIE 1931 color space.

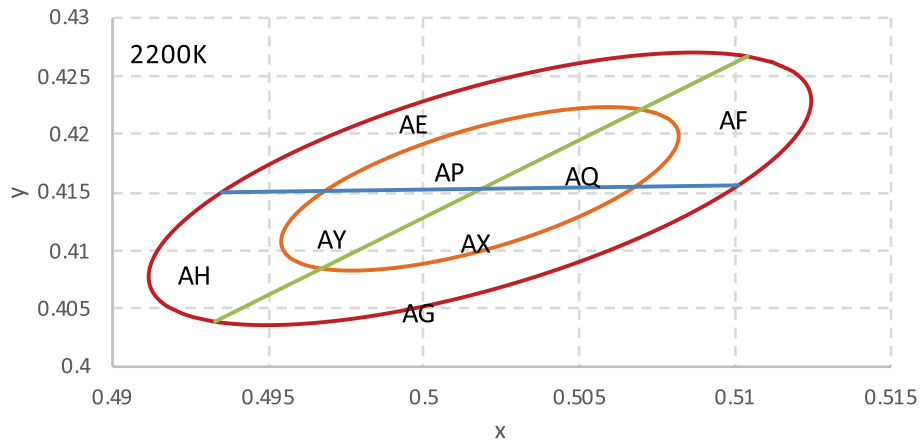

Figure 8j. 1/8th color bin structure for LUXEON 2835 HE and LUXEON 2835N 3V 2200K at specified test current and binning temperature of $T_j=25^{\circ}\text{C}$.

Table 6j-1. 3- and 5-step MacAdam ellipse color bin definitions for LUXEON 2835 HE and LUXEON 2835N 3V 2200K, at specified test and binning conditions.

NOMINAL CCT	COLOR SPACE	CENTER POINT ⁽¹⁾ (cx, cy)	MAJOR AXIS, a	MINOR AXIS, b	ELLIPSE ROTATION ANGLE, θ
2200K	Single 3-step MacAdam ellipse	(0.5018, 0.4153)	0.00863	0.00398	49.27°
2200K	Single 5-step MacAdam ellipse	(0.5018, 0.4153)	0.01438	0.00663	49.27°

Table 6j-2. 4 quadrants definition for LUXEON 2835 HE and LUXEON 2835N 3V 2200K, at specified test and binning conditions.

POINT	x	y
1	0.5104	0.4267
2	0.4935	0.4150
3	0.4933	0.4039
4	0.5101	0.4156
Center	0.5018	0.4153

Notes for Table 6j:

- Lumileds maintains a tolerance of ± 0.007 on x and y color coordinates in the CIE 1931 color space.

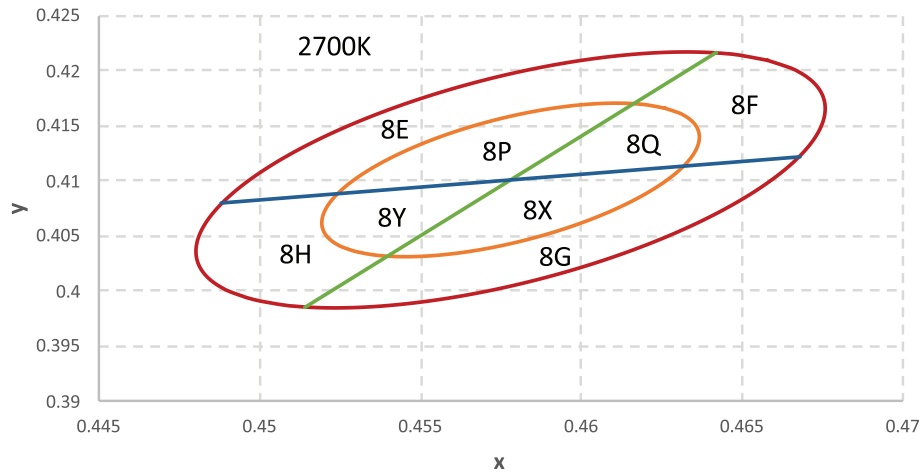

Figure 8k. 1/8th color bin structure for LUXEON 2835 HE and LUXEON 2835N 3V 2700K at specified test current and binning temperature of $T_j=25^{\circ}\text{C}$.

Table 6k-1. 3- and 5-step MacAdam ellipse color bin definitions for LUXEON 2835 HE and LUXEON 2835N 3V 2700K, at specified test and binning conditions.

NOMINAL CCT	COLOR SPACE	CENTER POINT ^[1] (cx, cy)	MAJOR AXIS, a	MINOR AXIS, b	ELLIPSE ROTATION ANGLE, θ
2700K	Single 3-step MacAdam ellipse	(0.4578, 0.4101)	0.00810	0.00420	53.70°
2700K	Single 5-step MacAdam ellipse	(0.4578, 0.4101)	0.01350	0.00700	53.70°

Table 6k-2. 4 quadrants definition for LUXEON 2835 HE and LUXEON 2835N 3V 2700K, at specified test and binning conditions.

POINT	x	y
1	0.4642	0.4217
2	0.4488	0.4080
3	0.4514	0.3985
4	0.4668	0.4122
Center	0.4578	0.4101

Notes for Table 6k:

- Lumileds maintains a tolerance of ± 0.007 on x and y color coordinates in the CIE 1931 color space.

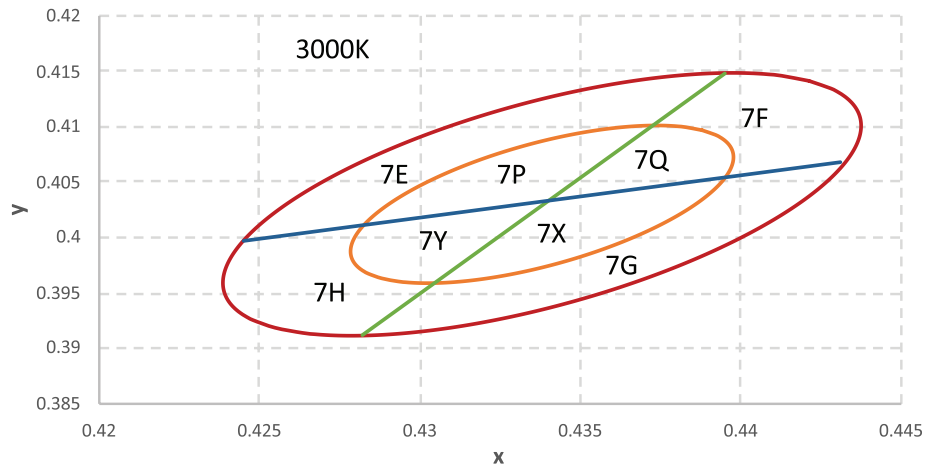

Figure 8I. 1/8th color bin structure for LUXEON 2835 HE and LUXEON 2835N 3V 3000K at specified test current and binning temperature of $T_j=25^{\circ}\text{C}$.

Table 6I-1. 3- and 5-step MacAdam ellipse color bin definitions for LUXEON 2835 HE and LUXEON 2835N 3V 3000K, at specified test and binning conditions.

NOMINAL CCT	COLOR SPACE	CENTER POINT ⁽¹⁾ (cx, cy)	MAJOR AXIS, a	MINOR AXIS, b	ELLIPSE ROTATION ANGLE, θ
3000K	Single 3-step MacAdam ellipse	(0.4338, 0.4030)	0.00834	0.00408	53.22°
3000K	Single 5-step MacAdam ellipse	(0.4338, 0.4030)	0.01390	0.00680	53.22°

Table 6I-2. 4 quadrants definition for LUXEON 2835 HE and LUXEON 2835N 3V 3000K, at specified test and binning conditions.

POINT	x	y
1	0.4395	0.4148
2	0.4245	0.3997
3	0.4282	0.3912
4	0.4431	0.4062
Center	0.4338	0.4030

Notes for Table 6I:

1. Lumileds maintains a tolerance of ± 0.007 on x and y color coordinates in the CIE 1931 color space.

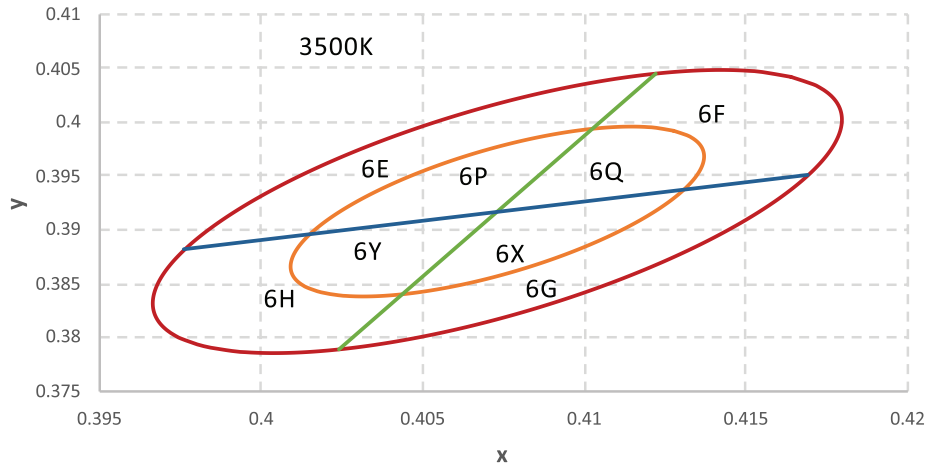

Figure 8m. 1/8th color bin structure for LUXEON 2835 HE and LUXEON 2835N 3V 3500K at specified test current and binning temperature of $T_j=25^{\circ}\text{C}$.

Table 6m-1. 3- and 5-step MacAdam ellipse color bin definitions for LUXEON 2835 HE and LUXEON 2835N 3V 3500K, at specified test and binning conditions.

NOMINAL CCT	COLOR SPACE	CENTER POINT ⁽¹⁾ (cx, cy)	MAJOR AXIS, a	MINOR AXIS, b	ELLIPSE ROTATION ANGLE, θ
3500K	Single 3-step MacAdam ellipse	(0.4073, 0.3917)	0.00927	0.00414	54.00°
3500K	Single 5-step MacAdam ellipse	(0.4073, 0.3917)	0.01545	0.00690	54.00°

Table 6m-2. 4 quadrants definition for LUXEON 2835 HE and LUXEON 2835N 3V 3500K, at specified test and binning conditions.

POINT	x	y
1	0.4122	0.4045
2	0.3976	0.3882
3	0.4024	0.3789
4	0.4169	0.3951
Center	0.4073	0.3917

Notes for Table 6m:

1. Lumileds maintains a tolerance of ± 0.007 on x and y color coordinates in the CIE 1931 color space.

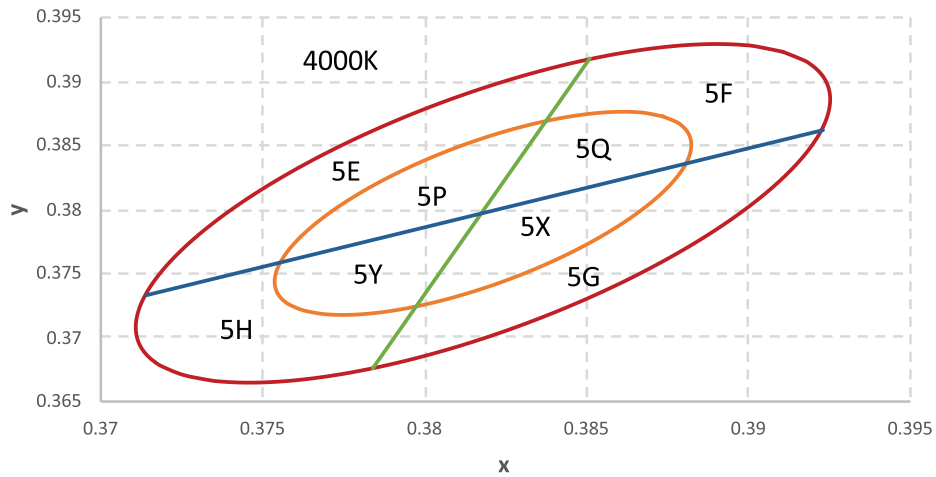

Figure 8n. 1/8th color bin structure for LUXEON 2835 HE and LUXEON 2835N 3V 4000K at specified test current and binning temperature of $T_j=25^{\circ}\text{C}$.

Table 6n-1. 3- and 5-step MacAdam ellipse color bin definitions for LUXEON 2835 HE and LUXEON 2835N 3V 4000K, at specified test and binning conditions.

NOMINAL CCT	COLOR SPACE	CENTER POINT ^[1] (cx, cy)	MAJOR AXIS, a	MINOR AXIS, b	ELLIPSE ROTATION ANGLE, θ
4000K	Single 3-step MacAdam ellipse	(0.3818, 0.3797)	0.00939	0.00402	53.72°
4000K	Single 5-step MacAdam ellipse	(0.3818, 0.3797)	0.01565	0.00670	53.72°

Table 6n-2. 4 quadrants definition for LUXEON 2835 HE and LUXEON 2835N 3V 4000K, at specified test and binning conditions.

POINT	x	y
1	0.3851	0.3918
2	0.3714	0.3733
3	0.3784	0.3676
4	0.3923	0.3862
Center	0.3818	0.3797

Notes for Table 6n:

1. Lumileds maintains a tolerance of ± 0.007 on x and y color coordinates in the CIE 1931 color space.

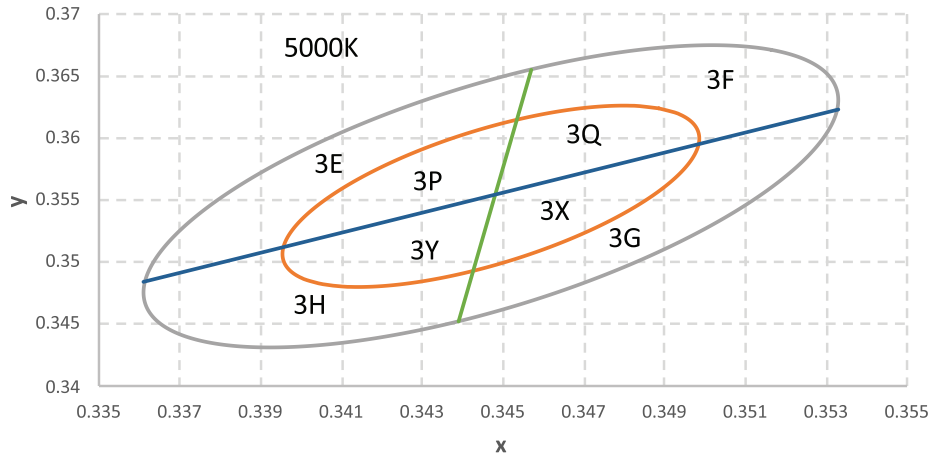

Figure 8o. 1/8th color bin structure for LUXEON 2835 HE and LUXEON 2835N 3V 5000K at specified test current and binning temperature of $T_j=25^{\circ}\text{C}$.

Table 6o-1. 3- and 5-step MacAdam ellipse color bin definitions for LUXEON 2835 HE and LUXEON 2835N 3V 5000K, at specified test and binning conditions.

NOMINAL CCT	COLOR SPACE	CENTER POINT ^[1] (cx, cy)	MAJOR AXIS, a	MINOR AXIS, b	ELLIPSE ROTATION ANGLE, θ
5000K	Single 3-step MacAdam ellipse	(0.3447, 0.3553)	0.00822	0.00354	59.62°
5000K	Single 5-step MacAdam ellipse	(0.3447, 0.3553)	0.01370	0.00590	59.62°

Table 6o-2. 4 quadrants definition for LUXEON 2835 HE and LUXEON 2835N 3V 5000K, at specified test and binning conditions.

POINT	x	y
1	0.3457	0.3655
2	0.3361	0.3484
3	0.3439	0.3452
4	0.3533	0.3623
Center	0.3447	0.3553

Notes for Table 6o:

1. Lumileds maintains a tolerance of ± 0.007 on x and y color coordinates in the CIE 1931 color space.

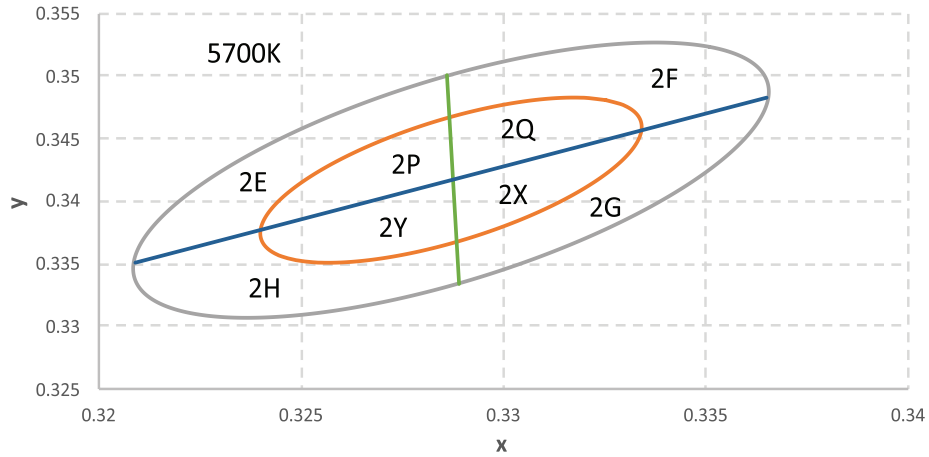

Figure 8p. 1/8th color bin structure for LUXEON 2835 HE and LUXEON 2835N 3V 5700K at specified test current and binning temperature of $T_j=25^{\circ}\text{C}$.

Table 6p-1. 3- and 5-step MacAdam ellipse color bin definitions for LUXEON 2835 HE and LUXEON 2835N 3V 5700K, at specified test and binning conditions.

NOMINAL CCT	COLOR SPACE	CENTER POINT ⁽¹⁾ (cx, cy)	MAJOR AXIS, a	MINOR AXIS, b	ELLIPSE ROTATION ANGLE, θ
5700K	Single 3-step MacAdam ellipse	(0.3287, 0.3417)	0.00746	0.00320	59.09°
5700K	Single 5-step MacAdam ellipse	(0.3287, 0.3417)	0.01243	0.00533	59.09°

Table 6p-2. 4 quadrants definition for LUXEON 2835 HE and LUXEON 2835N 3V 5700K, at specified test and binning conditions.

POINT	x	y
1	0.3286	0.3501
2	0.3209	0.3351
3	0.3289	0.3334
4	0.3365	0.3483
Center	0.3287	0.3417

Notes for Table 6p:

1. Lumileds maintains a tolerance of ± 0.007 on x and y color coordinates in the CIE 1931 color space.

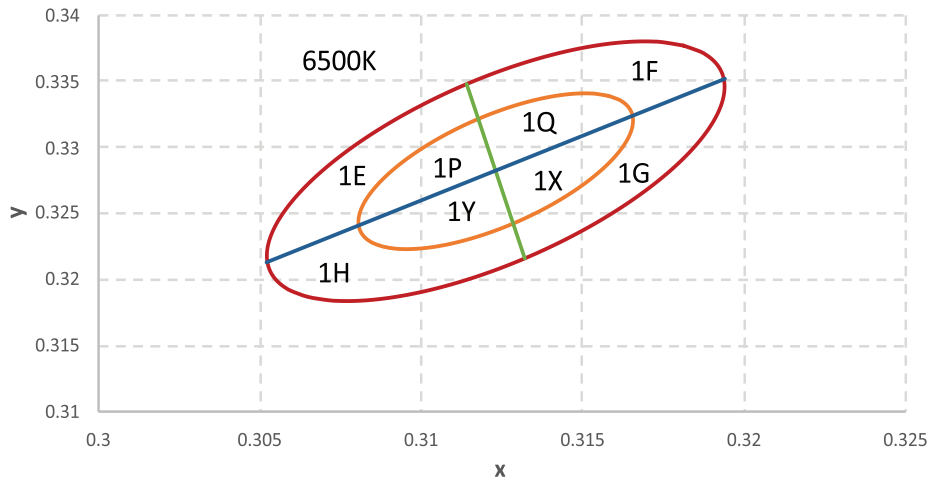

Figure 8q. 1/8th color bin structure for LUXEON 2835 HE and LUXEON 2835N 3V 6500K at specified test current and binning temperature of $T_j=25^{\circ}\text{C}$.

Table 6q-1. 3- and 5-step MacAdam ellipse color bin definitions for LUXEON 2835 HE and LUXEON 2835N 3V 6500K, at specified test and binning conditions.

NOMINAL CCT	COLOR SPACE	CENTER POINT ⁽¹⁾ (cx, cy)	MAJOR AXIS, a	MINOR AXIS, b	ELLIPSE ROTATION ANGLE, θ
6500K	Single 3-step MacAdam ellipse	(0.3123, 0.3282)	0.00669	0.00285	58.57°
6500K	Single 5-step MacAdam ellipse	(0.3123, 0.3282)	0.01115	0.00475	58.57°

Table 6q-2. 4 quadrants definition for LUXEON 2835 HE and LUXEON 2835N 3V 6500K, at specified test and binning conditions.

POINT	x	y
1	0.3114	0.3348
2	0.3052	0.3213
3	0.3132	0.3216
4	0.3194	0.3352
Center	0.3123	0.3282

Notes for Table 6q:

1. Lumileds maintains a tolerance of ± 0.007 on x and y color coordinates in the CIE 1931 color space.

Forward Voltage Bins

Table 7. Forward voltage bin definitions for LUXEON 2835 Architectural at specified test current, $T_j=25^{\circ}\text{C}$.

PRODUCT	BIN	FORWARD VOLTAGE ⁽¹⁾ (V _f)	
		MINIMUM	MAXIMUM
LUXEON 2835E 9V	U	8.40	8.70
	V	8.70	9.00
	W	9.00	9.30
	X	9.30	9.60
	Y	9.60	9.90
LUXEON 2835E 6V	U	5.60	5.80
	V	5.80	6.00
	W	6.00	6.20
	X	6.20	6.40
	Y	6.40	6.60
LUXEON 2835C 6V	G	5.80	6.00
	H	6.00	6.20
	J	6.20	6.40
	K	6.40	6.60
LUXEON 2835E 3V LUXEON 2835C 3V LUXEON 2835C 3V TVS	S	2.70	2.80
	T	2.80	2.90
	V	2.90	3.00
	W	3.00	3.10
	X	3.10	3.20
LUXEON 2835 HE 3V	Y	3.20	3.30
	K	2.66	2.76
LUXEON 2835N 3V	Q	2.68	2.78
	R	2.78	2.88

Notes for Table 7:

1. Lumileds maintains a tolerance of $\pm 0.10\text{V}$ on forward voltage measurements.

Mechanical Dimensions

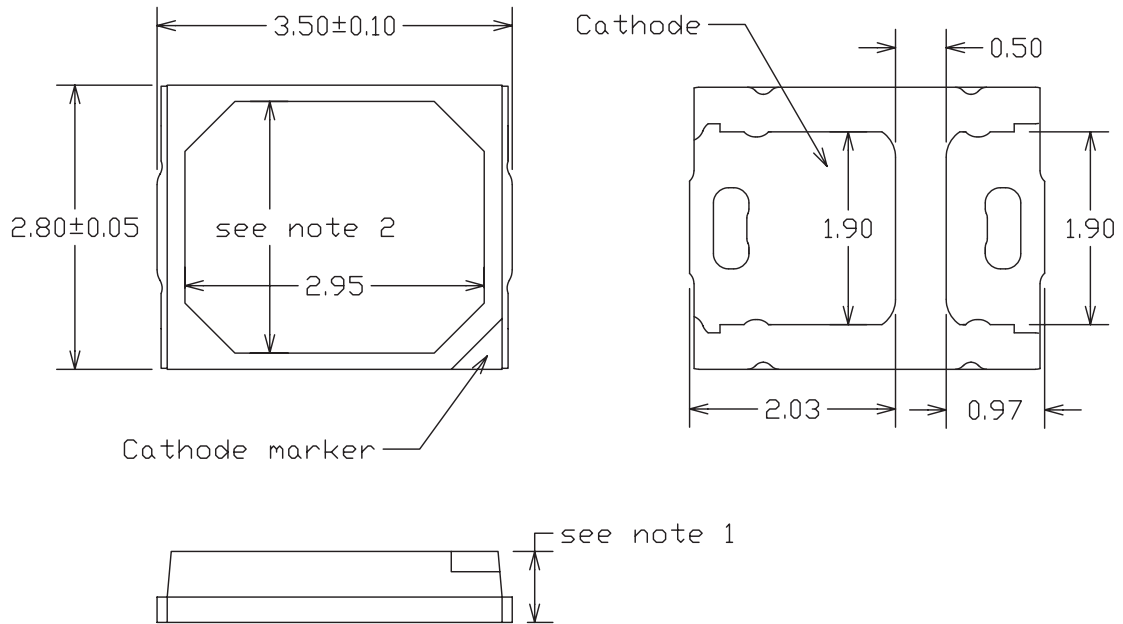

	LUXEON 2835E 3V	All Others
note 1	0.65 ± 0.05	0.70 ± 0.05
note 2	2.53	2.48

Figure 9. Mechanical dimensions for LUXEON 2835 Architectural.

Notes for Figure 9:

1. Drawings are not to scale.
2. All dimensions are in millimeters.

Reflow Soldering Guidelines

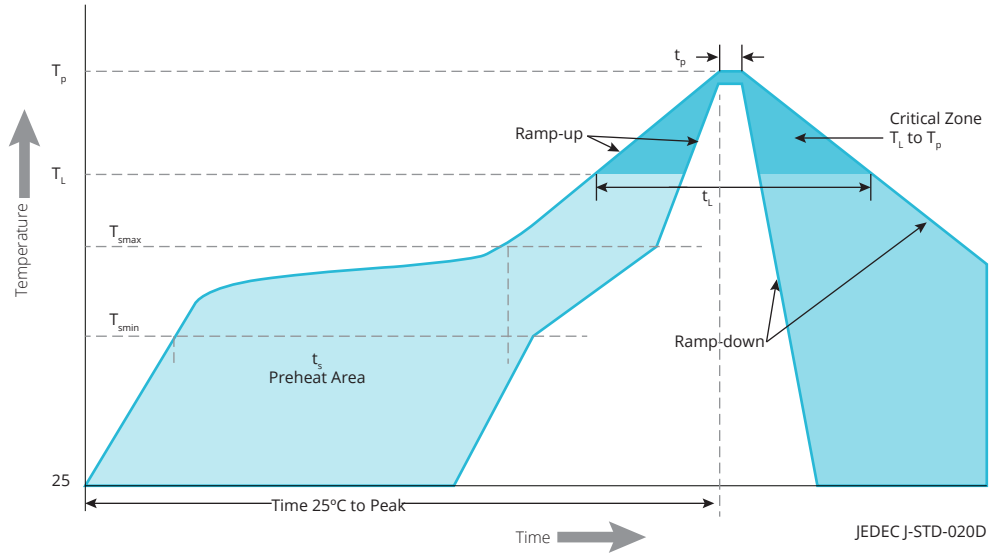

Figure 10. Visualization of the acceptable reflow temperature profile as specified in Table 8.

Table 8. Reflow profile characteristics for LUXEON 2835 Architectural.

PROFILE FEATURE	LEAD-FREE ASSEMBLY
Preheat Minimum Temperature (T_{smin})	150°C
Preheat Maximum Temperature (T_{smax})	200°C
Preheat Time (t_{smin} to t_{smax})	60 to 120 seconds
Ramp-Up Rate (T_L to T_p)	3°C / second maximum
Liquidus Temperature (T_L)	217°C
Time Maintained Above Temperature T_L (t_L)	60 to 150 seconds
Peak / Classification Temperature (T_p)	260°C
Time Within 5°C of Actual Temperature (t_p)	20 to 40 seconds
Ramp-Down Rate (T_p to T_L)	6°C / second maximum
Time 25°C to Peak Temperature	8 minutes maximum

JEDEC Moisture Sensitivity

Table 9. Moisture sensitivity levels for LUXEON 2835 Architectural.

LEVEL	FLOOR LIFE		SOAK REQUIREMENTS STANDARD	
	TIME	CONDITIONS	TIME	CONDITIONS
3	168 Hours	≤30°C / 60% RH	192 Hours +5 / -0	30°C / 60% RH

Solder Pad Design

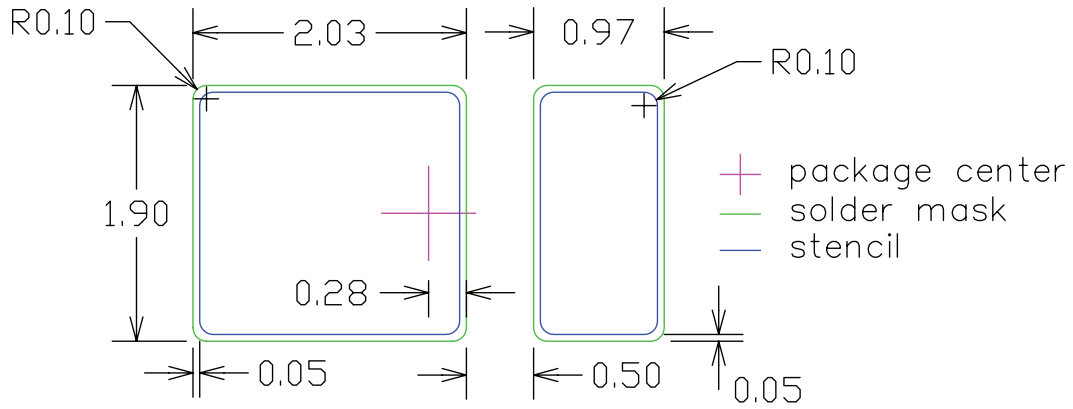

Figure 11. Recommended PCB solder pad layout for LUXEON 2835 Architectural.

Notes for Figure 11:

1. Drawings are not to scale.
2. All dimensions are in millimeters.

Packaging Information

Pocket Tape Dimensions

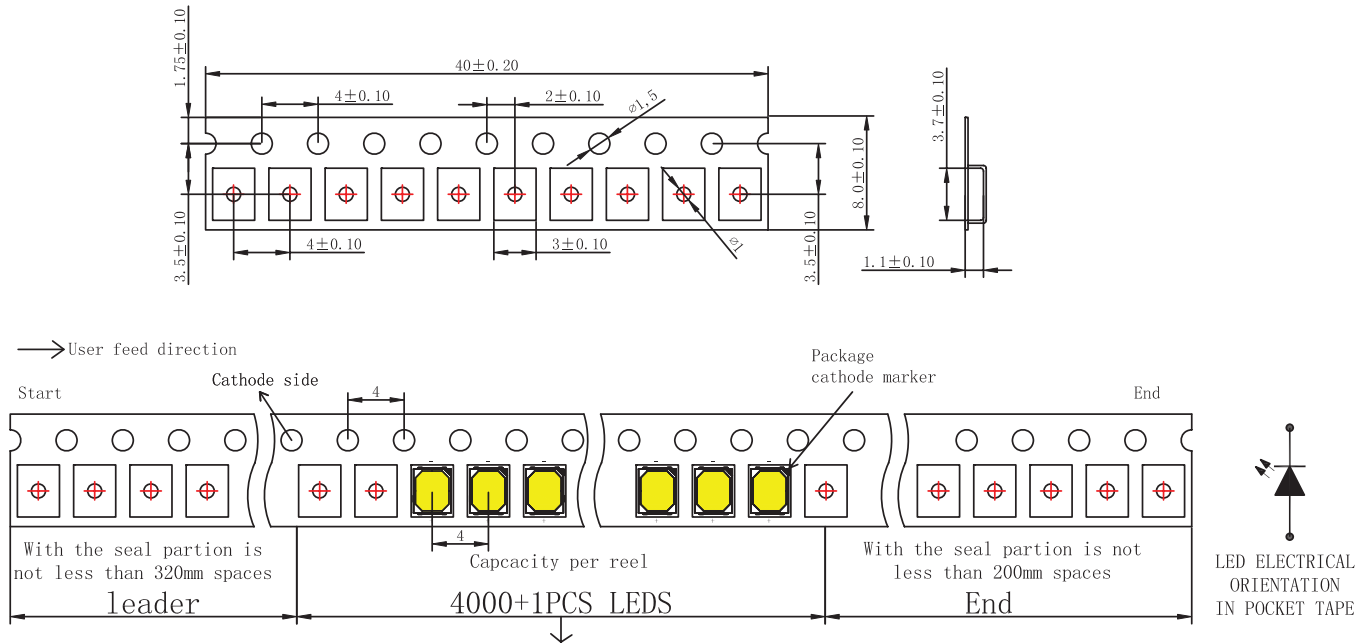

Figure 12. Pocket tape dimensions for LUXEON 2835 Architectural.

Notes for Figure 12:

1. Drawings are not to scale.
2. All dimensions are in millimeters.

Reel Dimensions

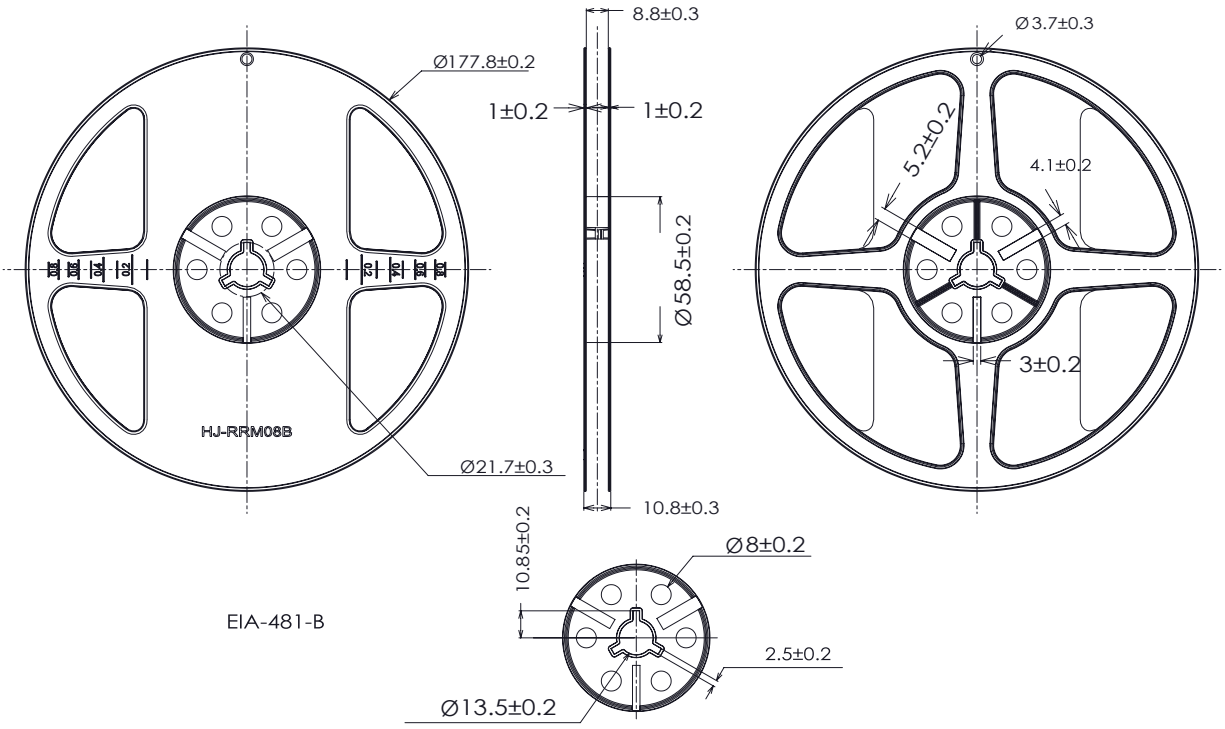

Figure 13. Reel dimensions for LUXEON 2835 Architectural.

- Notes for Figure 13:
1. Drawings are not to scale.
 2. All dimensions are in millimeters.

About Lumileds

Companies developing automotive, mobile, IoT and illumination lighting applications need a partner who can collaborate with them to push the boundaries of light. With over 100 years of inventions and industry firsts, Lumileds is a global lighting solutions company that helps customers around the world deliver differentiated solutions to gain and maintain a competitive edge. As the inventor of Xenon technology, a pioneer in halogen lighting and the leader in high performance LEDs, Lumileds builds innovation, quality and reliability into its technology, products and every customer engagement. Together with its customers, Lumileds is making the world better, safer, more beautiful—with light.

To learn more about our lighting solutions, visit lumileds.com.



©2024 Lumileds Holding B.V. All rights reserved.
LUXEON is a registered trademark of the Lumileds Holding B.V. in the United States and other countries.

lumileds.com

Neither Lumileds Holding B.V. nor its affiliates shall be liable for any kind of loss of data or any other damages, direct, indirect or consequential, resulting from the use of the provided information and data. Although Lumileds Holding B.V. and/or its affiliates have attempted to provide the most accurate information and data, the materials and services information and data are provided "as is," and neither Lumileds Holding B.V. nor its affiliates warrants or guarantees the contents and correctness of the provided information and data. Lumileds Holding B.V. and its affiliates reserve the right to make changes without notice. You as user agree to this disclaimer and user agreement with the download or use of the provided materials, information and data. A listing of Lumileds product/patent coverage may be accessed at lumileds.com/patents.