

HIGH-BAY LIGHTING ASTRA



Description:

ASTRA LED UFO highbay luminaires are designed to deliver innovative lighting for industrial applications.

They ensure brilliance illumination while reducing energy consumption and maintenance costs.



L70B10

Specifications:

Wattage	Lumen	Efficacy	Power Factor	CRI	CCT	Voltage	Frequency	Dimensions (mm)	
								D	H
100W	12500lm	125lm/w	>0.95	≥ 80	3000-6500K	85-305 VAC	50 Hz	290	120
150W	18750lm	125lm/w	>0.95	≥ 80	3000-6500K	85-305 VAC	50 Hz	340	135
200W	25000lm	125lm/w	>0.95	≥ 80	3000-6500K	85-305 VAC	50 Hz	386	135

Features:

Body Material	Finishing	Optics	Driver	Driver Mounting	Beam Angle
Die Cast Aluminium	Electrostatic Painting	Tempered Glass	Included	Separated - On Housing	100°

Photometric:

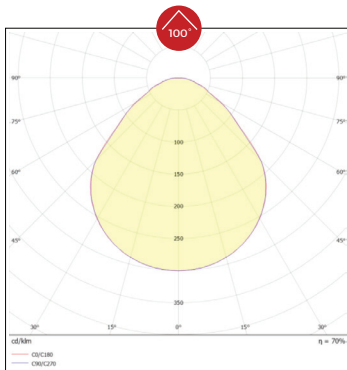

General Dimensions:

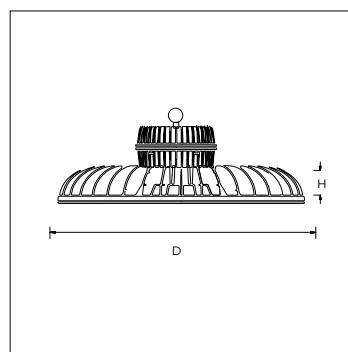

Body Finish:

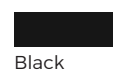

Applications:

